

General technical data

1. BASIC CONSTRUCTION

Structure of an electrolytic aluminum capacitor is shown hereunder:

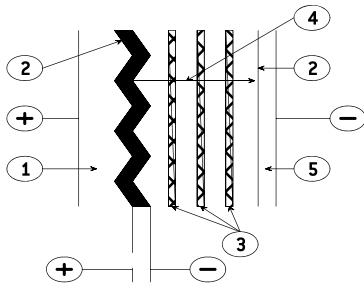

1. Anode: aluminum foil
2. Dielectric: aluminum oxide
3. Papers spacers impregnated with electrolyte
4. Ionic conduction assumed by electrolyte
5. Cathode: aluminum foil

The positive plate is an etched aluminum foil covered with alumina which is the dielectric of the capacitor.

The negative plate is constituted by a second aluminum foil which serves as a current supply, and by electrolyte-impregnated papers layers.

The metal used for anode is a $\geq 99,98\%$ grade aluminum.

The dielectric has a thickness of $13 \text{ \AA} / \text{V}$.

The aluminum used for the cathode is a $\geq 98\%$ grade aluminum covered with a dielectric layer with a thickness of about 40 \AA .

2. DIAGRAM OF THE EQUIVALENT CIRCUIT

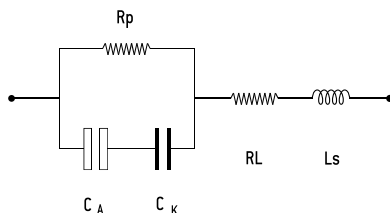

- C_A = Capacitance of the anode
 C_K = Capacitance of the cathode
 R_p = Parallel resistance due to the aluminum oxide film.
 R_L = Series resistance of connections, plates and impregnated spacer.
 L_s = Inductance of winding and connections.

A standard simplified diagram is.

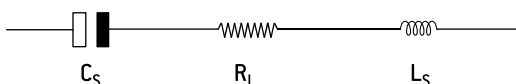

C_s is the series capacitance of both anode and cathode capacitances. Electrolytic aluminum capacitors are naturally polarized because of the insulating film on the anode. Given the very thin aluminum oxide layer, a reversed voltage should not exceed 1.5 V when there is energy supply.

Short duration reverse voltages can be absorbed by special construction, second anode replacing the former cathode.

3. CAPACITORS MARKING

3.1. ARTICLE CODE (ON EACH PACKAGING)

A followed by 6 figures number. First 3 positions are specific of the range. (Ex. A 745xxx for a FELSIC 85 BD)

140 FELSIC in bank	741 FELSIC 125 FRS BD (ex 731)
701 PRORELSIC 125	742 PRORELSIC 105 TFRS
703 PRORELSIC 125	743 PRORELSIC 105 TFRS
704 SNAPSIC	744 FELSIC 85 BC
705 SNAPSIC 105	FELSIC 85 LP
706 FELSIC HP BC – BD	745 FELSIC 85 BD
708 PRORELSIC 145	746 FELSIC 85 M BC
710 CUBISIC	747 FELSIC 85 M BD
711 PROMISIC 031	748 SICAL CO 42 - SICAL
712 CUBISIC LP	749 SICAL CO 42 - SICAL
713 SNAPSIC 105 LP	750 CUBISIC 125
714 SNAPSIC 4P	756 FELSIC 105 BC
715 SNAPSIC 105 4P	FELSIC 105 LP
716 SNAPSIC HV	757 FELSIC 105 BD
717 SNAPSIC HC	760 FELSIC HC BC
718 SNAPSIC 125	761 FELSIC HC BD
721 RELSIC 033	762 FELSIC 105 TFRS BC
722 CI FRS	763 FELSIC 105 TFRS BD
723 CI FRS	764 FELSIC HV BC
728 FELSIC 039 (ex 727)	765 FELSIC HV BD
FELSIC DI	775 VACSIC
738 FELSIC 037 (ex 737)	774 VACSIC 150
740 FELSIC 125 FRS BC (ex 731)	776 ALSIC 20G
	ALSIC 145 20G

In FELSIC ranges, article code without first letter A, is printed on each capacitor.

a Figure 9 in fourth position shows a special product.

3.2. BATCH (ON EACH CAPACITOR).

3 figures or 6 figures

3.3. DATE (ON EACH CAPACITOR IF APPLICABLE)

4 figures (year-week)

4. ELECTRICAL CHARACTERISTICS

4.1. RATED CAPACITANCE C_R

The rated capacitance is defined at 100 Hz and at ambient temperature.

4.2. RATED VOLTAGE U_R

U_R is the maximum DC voltage which may be applied in continuous operation.

When applying a superimposed alternating voltage, the peak value of the resulting waveform should not exceed the rated voltage.

4.3. PEAK VOLTAGE U_p

U_p is the maximum repetitive voltage which can be applied within short periods.

Defined in CECC 30 300 and IEC 60 384-4:

1000 cycles of 30 s charge followed by a no load period of 5 min. 30 s with upper category temperature.

$$U_p \leq 1,15 U_R \quad (U_R \leq 315 \text{ V})$$

$$U_p \leq 1,10 U_R \quad (U_R > 315 \text{ V})$$

4.4. DISSIPATION FACTOR TANδ

The dissipation or loss factor is defined by its tangent $\text{Tan}\delta$

$$\text{Tg}\delta = R_s C_s \omega$$

$$(\omega = 2\pi F)$$

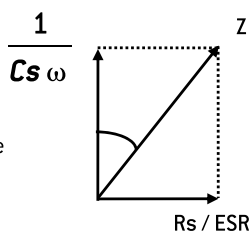

- ESR** Capacitor Equivalent Series Resistance
Cs Capacitor capacitance
F Frequency (100 Hz)
Z Capacitor impedance

4.5. EQUIVALENT SERIES RESISTANCE ESR

The relation between ESR and dissipation factor $\text{Tan}\delta$ is given in § 4.4.

4.6. IMPEDANCE Z - INDUCTANCE L

The impedance is given by:

$$Z = \sqrt{R^2 + \left[L\omega - \frac{1}{C\omega}\right]^2}$$

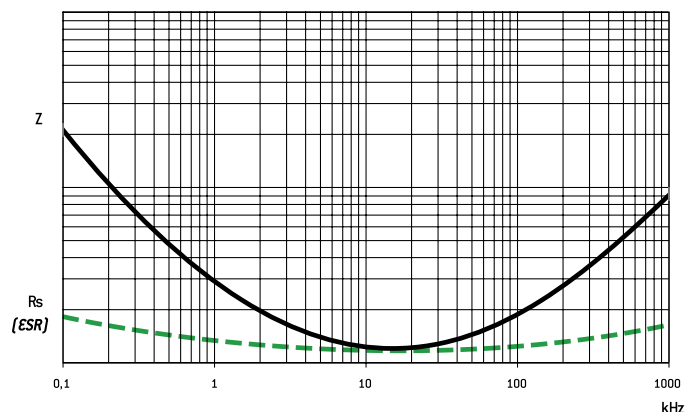

L inductance. Generally $L = 5$ to 20 nH
 Z and ESR as function of frequency typically follows the chart:

4.7. PERMISSIBLE RIPPLE CURRENT (I r.m.s.) I~

The current is defined at the maximum climatic category and at 100 Hz. It is the root mean square value r.m.s. The value I_0 is the rated value for calculations of expected life up to $3 I_0$.

4.8. LEAKAGE CURRENT II

I_l is measured at 20°C after a 5 min. polarization under rated voltage.

For C_R in μF and U_R in V:

$$I_l \leq 0,01 C_R U_R \text{ or } 1 \mu\text{A}^*$$

when $C_R U_R \leq 1000 \mu\text{C}$

$$I_l \leq 0,006 C_R U_R + 4 \mu\text{A}$$

when $C_R U_R > 1000 \mu\text{C}$

For $U_R > 350 \text{V}_{\text{DC}}$ it can be specified:

with $K = 4, 6$ or 8

or

$$I_l \leq 0,3 (C_R U_R)^{0,7} + 4 \mu\text{A} \text{ (CECC 30 300)}$$

* Whichever is the greater

4.9. CHARACTERISTICS

Versus temperature (typical values).

4.9.1. Capacitance drift

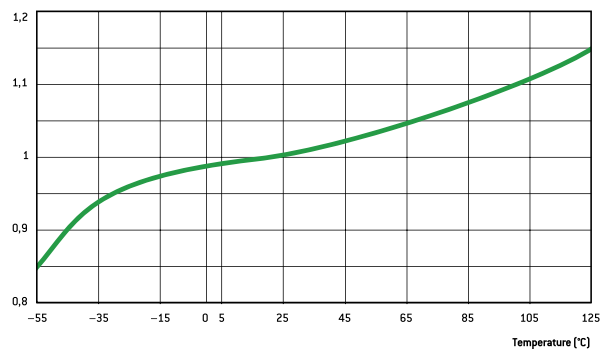

Versus temperature

4.9.2. ESR and Z drifts at 100 Hz

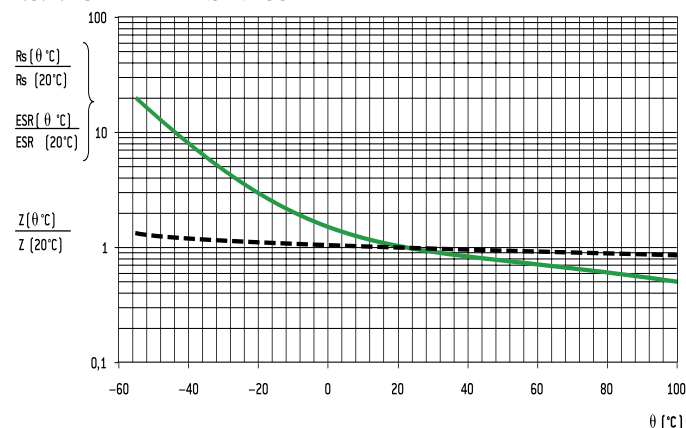

Versus temperature

4.9.3 Leakage current drift

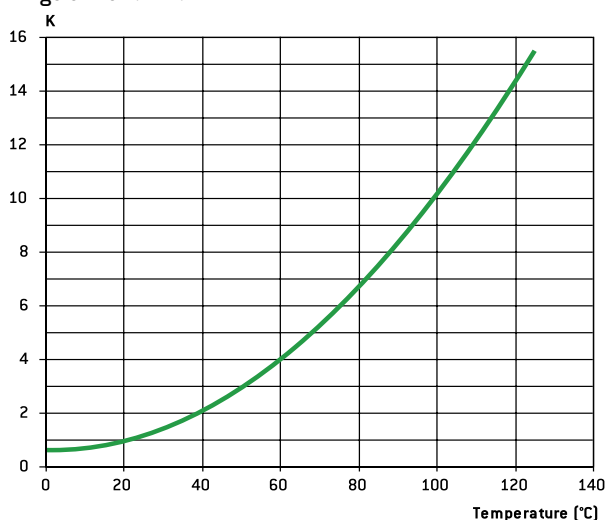

Versus temperature

General technical data

5. SPECIFICATION TO APPLY

Electrolytic aluminum capacitors are defined in:

- NF and UTE French national standard
- CECC European specifications
- IEC international specifications

Quality insurance procedures are described in these specifications.

	French	European	International
Generic specification Fixed capacitors	NF C 83 100	CECC 30 000 EN 130 000	IEC 60 384 -1 QC 300 000
Sectional specification Electrolytic aluminum capacitors	NF C 83 110	CECC 30 300	IEC 60 384 - 4 C 300 300
Blank deta II specification - Electrolytic aluminum capacitors with non solid electrolyte.	UTE 83 110	CECC 30 301	IEC 60 384 - 4 -1 QC 300 301
Blank deta II specifications	CECC 30 301- 017 to CECC 30 301- 062 C0 31 to C0 55	CECC 30 301- 017 to CECC 30 301- 062 CECC 30 301- 802 to CECC 30 301- 811	

6. ENDURANCE TESTS / LIFE TIME

6.1. STANDARD ENDURANCE TEST

at max category temperature:

Standard endurance tests do not exceed 2000 hours at 125°C. However,

Temperature	Endurance test			
	Grade I - Long life			Grade II - General purpose
	10 000 h	5 000 h	2 000 h	1 000 h
125°C			•	
105°C		•	•	•
85°C	•	•	•	•

present EXXELIA technologies concerning liquid electrolytes have led to endurance tests up to 5000 hours at 125°C (PRORELSIC 125 - FELSIC 125 RS) and even 20000 hours at 125°C (PRORELSIC 145 - ALSIC 145)

6.2. PERFORMANCE REQUIREMENTS ON STANDARD ENDURANCE TESTS.

Permissible capacitance drift $\Delta C/C$ (%)

Permissible increase factors on $\tan\delta$, ESR, Z and II initial values

(1) $\tan\delta$ or ESR: for initial value, take standard value.

U_R	Endurance test			
	Grade I			Grade II
	10 000 h	5 000 h	2 000 h	1 000 h
6,3 V			+15 -30	+25 -40
10 V - 35 V	+15 -20	±15	±15	±30
40 V - 160 V	±15	±15	±15	±30
> 160 V	±15	±10	±10	±15

	Endurance test			
	Grade I			Grade II
	10 000 h	5 000 h	2 000 h	1 000 h
$\tan\delta$ or ESR [1]	1,5	1,3	1,3	1,5
Z [2]	3	2	2	3
II	Standard values			

[2] Z: for initial value, take specified value [see data sheet].

Specific requirements can be taken into consideration with regards to initial values of dissipation factor or equivalent series resistance and impedance.

6.3. FAILURE CRITERIA FOR ELECTROLYTIC CAPACITORS.

Failure criteria are defined in CECC 30 301

- Non measurable defaults leading to complete failure.
- Measurable defaults leading to adjustment losses of the load circuit (failure due to variations).

6.3.1. Non measurable defaults.

They might be summed up as:

- Open circuit
- Short circuit
- Operation of pressure relief device
- Severely damaged insulation
- Unusable terminations

6.3.2. Measurable defaults.

Variations exceeding the values given below characterize a default.

- Capacitance drift $\Delta C/C$ (%): 3 times the limit for standard endurance testing or 50 % (whichever is the smallest).
- $\tan\delta$ or ESR: 3 times standard max initial values.
- Z: 3 times standard max initial values.
- II: initial limit (under load conditions).

Specific requirements can be taken into consideration with regards to lower drifts.

6.4. INFLUENCE OF MAIN PARAMETER ON OPERATIONAL LIFE.

6.4.1. Temperature.

The capacitors operational life is highly dependent upon its internal temperature Θ_i and therefore upon the ambient temperature and the ripple current.

Knowing ESR and dissipated power values (§ 6.4.3.) one can figure out, the internal temperature rise and then determine the capacitors expected life.

With present high boiling point electrolytes (§ 8.6)

Θ_i max = 125 to 185°C depending on styles.

6.4.2. Ripple current.

The ripple current flowing through the capacitor increase the internal temperature through power dissipation.

Standards define the permissible current at 100 Hz and generally consider a temperature rise of 5 to 10°C of max category temperature.

Current waveforms and frequencies make it difficult to clearly determine the capacitors internal temperature rise, which defines the operationally life.

Experiments confirm following relationship:

$$\Theta_i = \Theta_a + (\Theta_c - \Theta_a) K$$

Where:

- Θ_i = Internal hot spot temperature
- Θ_a = Ambient temperature
- Θ_c = Case temperature
- K = Parameter depending upon case diameter and cooling
 - $\emptyset \geq 51$ k = $2 \pm 0,5$
 - $\emptyset < 51$ k = $1,5 \pm 0,5$ [air cooling - 0,2 m/s]

General technical data

r.m.s. value according to current waveform.

one capacitor diameter

Function	Mean value	R.m.s. value	Function	Mean value	R.m.s. value	Function	Mean value	R.m.s. value
	$A (t_0/T)$	$A \sqrt{t_0/T}$		$A/2$	$A \sqrt{3}$		$2A/\pi$	$A/\sqrt{2}$
	$A (t_1/T)$	$A \sqrt{2t_1/3T}$		$2A/\pi (t_0/T)$	$A \sqrt{t_0/2T}$		$A/2$	$A/\sqrt{3}$
	$A/2 (t_0/T)$	$A \sqrt{t_0/3T}$		$A/2 (t_0/T)$	$A \sqrt{t_0/3T}$		0	A

6.4.3. Dissipated power versus case dimension

For calculations of ripple currents, considering an internal

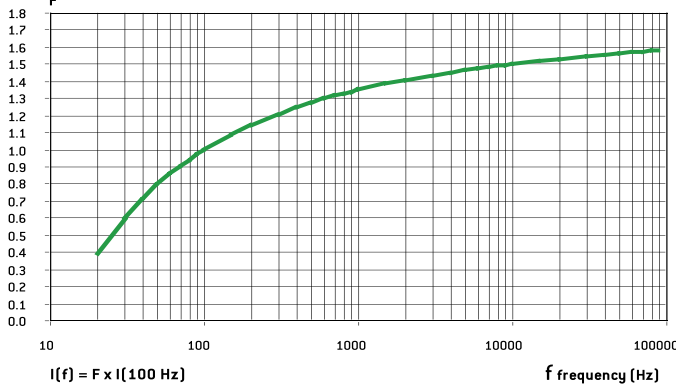
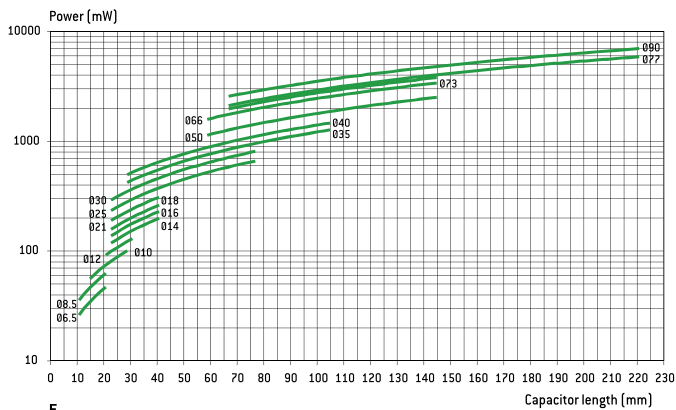

temperature rise of 10°C
 $P = ESR \cdot I^2$

P = Dissipated power (mW)
 $(\Theta_i - \Theta_a = 10^\circ\text{C})$

ESR: Equivalent series resistance (100 Hz 20°C)

I: Ripple current (r.m.s. value at 100 Hz)

For different frequencies from 100 Hz, I must be multiplied by the factor F, according to above chart.

6.4.4. Thermal resistance Rth and air cooling

Rth is static thermal resistance (without cooling) between capacitor central hot spot and ambient temperature measured at a distance of

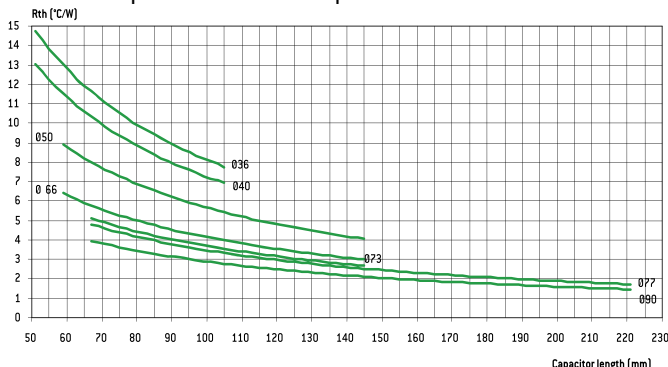

Forced or not cooling air can lead to a significant decrease of these values.

Consequently, r.m.s. ripple current can be increased as a function of air cooling speed:

Ø mm (inches)	≤ 0,5 m/s	1 m/s	2 m/s	3 m/s	≥ 4 m/s
66 - 90	1~	1,1~	1,2~	1,25~	1,3~
36 - 51	1~	1,2~	1,4~	1,45~	1,5~

This parameter shall be applied to one capacitor alone.

For capacitors in bank, ambient temperature must be strictly equal around all capacitors.

6.4.5. Quality guaranty

We guarantee products manufactured during 2 years from the data of shipment against defaults of material and assembly.

This guaranty can be involved by the buyer only if our products are used within normal conditions, always according to the state of the art and taking in account storage conditions.

The equipment design should take into consideration possible failures of our capacitors and related effects in order to avoid them.

Guaranty is not applicable for damages occurred by surge voltage, irregular use, polarity inversion or maintenance default.

Guaranty is exclusively limited to the replacement of individual defective capacitors within the terms of delivery. This rule applied to all cases and particularly to any further consequence of failures.

6.4.6. Reliability

Failure rate: _____

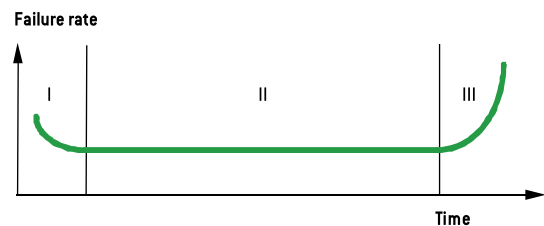

$$FR = \frac{\text{Number of components tested} \times \text{test duration}}{\text{Number of failures}}$$

Failure rate is measured in FIT (failure in time = 10^{-9} / hour).

The failure rate is set up during the life time of the capacitor (phase II)

I. Early failure phase (generally excluded during ageing process).

II. Operational life time of the capacitors

III. End of life

General technical data

Mean time between failures MTBF = 1/FR mesured in years

Range	Failure rate for a failure percentage not exceeding 1% with a confidence level of 60 %
FELSIC 85 >350 V FELSIC HC > 350 V SNAPSIC - SNAPSIC HC > 350 V SNAPSIC 4P > 350 V PROMISIC 031 Ø = 6,5 SICAL CO 42 - SICAL > 350 V	50 FIT - (MTBF = 2280)
FELSIC 037 - 039 FELSIC 85 ≤ 350 V FELSIC HC ≤ 350 V CUBISIC CI FRS SNAPSIC 105 - SNAPSIC 105 4P SNAPSIC 105 LP - SNAPSIC HV SNAPSIC - SNAPSIC 4P ≤ 350 V SNAPSIC HC ≤ 350 V ALSIC IR - ALSIC 145 - ALSIC HV - VACSIC 150 - VACSIC SICAL CO 42 - SICAL ≤ 350 V PRORELSIC 125 Ø = 6,5 RELSIC 033 PROMISIC 031 Ø > 6,5	25 FIT - (MTBF = 4560)
FELSIC 125 FRS - SNAPSIC 125 FELSIC HV - FELSIC 105	10 FIT - (MTBF = 11410)
PRORELSIC 125 Ø > 6,5 PRORELSIC 145	5 FIT - (MTBF = 22820)

Multiplying factor of FR with voltage and temperature

	Temperature (°C)							
	≤ 40	50	60	70	85	105 (1)	125 (1)	145 (1)
Factor	1	1,5	2,3	3,4	6,3	14	32	72

(1) Only for permitted capacitors

	Percentage of rated voltage (2)		
	100 %	80 %	50 %
Factor	1	0,8	0,5

(2) This voltage has to be constant

Environ- ment	Without vibration		Ground with vibrations or mob ile			
	Ground, fix Controlled air	Ground, fix	PRORELSIC SNAPSIC 20 g FELSIC 20 g	FELSIC 10 g PROMISIC SICAL Ø ≤14	CI FRS - SNAPSIC RELSIC SICAL Ø >14	ALSIC
Factor	1	2	2	4	6	12

7. MANUFACTURING FLOW CHART

Process controls

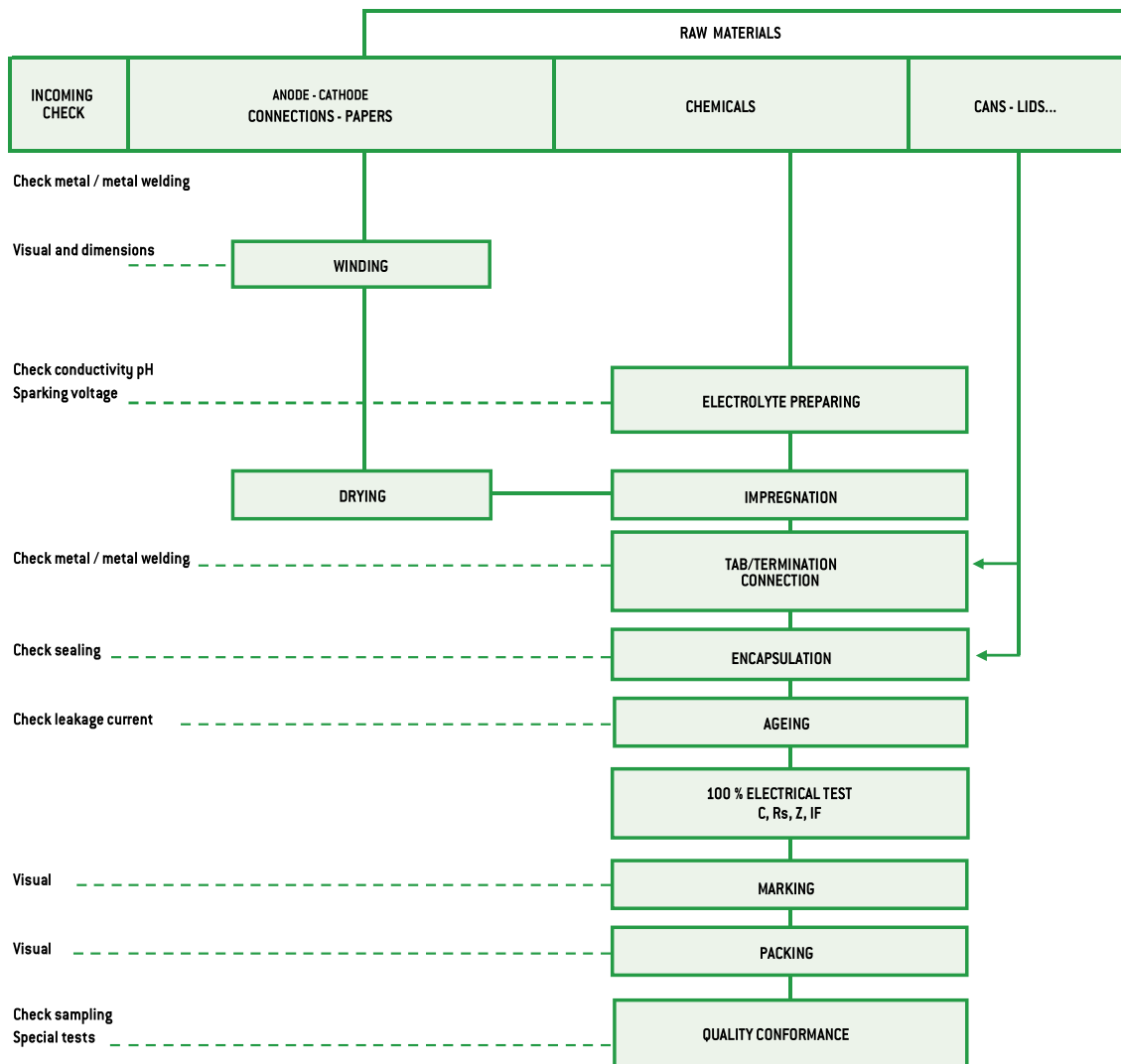

General technical data

8. INFORMATION ON APPLICATION

8.1. CLEANING SOLVENTS

Use aliphatic alcohols, such as denatured ethyl alcohol, isopropanol, or butylacetate, or else alkaline diluted solutions. Avoid incompatible solvents (halogenous for example).

8.2. SHELF LIFE

There is no electrical characteristics variation for long periods of storage except leakage current which can increase.

It is caused by chemical reactions between the dielectric alumina and the electrolyte. These reactions are reversible when switched on. Capacitors can generally be stored at temperature between -5° and $+50^{\circ}\text{C}$ without reforming for the following periods of time:

- For $U_R \leq 100\text{ V}$, storage time: 5 years (up to 10 years under specific conditions)
- For $100\text{ V} < U_R \leq 360\text{ V}$ storage time: 3 years
- For $360\text{ V} < U_R < 500\text{ V}$ storage time: 1 year
- For $U_R \leq 500\text{ V}$, storage time: 6 months

Generally when these periods are overstepped, one hour at rated voltage causes the decrease of leakage current under the specified limits. An other way to avoid this leakage current increase problem is to always limit available power through capacitor during first seconds or minutes after storage or transport, according to the following chart:

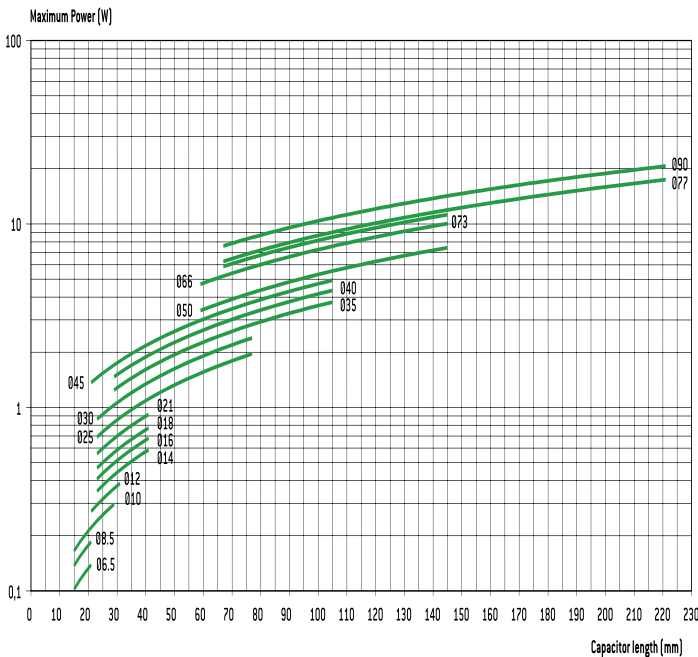

8.3. LOW PRESSURE RESISTANCE

EXXELIA capacitors can be used with ambient low pressure decreasing up to 10 mbar (altitude 28000 m – 92000 feet).

8.4. MOUNTING SCREW TERMINALS CAPACITORS (FELSIC)

Capacitors may be used vertically (terminals on top) or horizontally. When used horizontally, the following position in relation to the safety vent, is recommended:

Mounting capacitors in series may be used for operating voltage exceeding U_R . See FELSIC in bank.

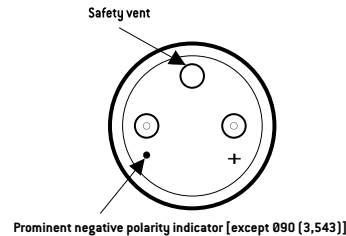

8.5. MOUNTING SOLDER TYPE CAPACITORS.

They may be used in any position. During mounting, avoid applying excessive force to capacitor pins or wires. There is a risk of damaging internal connections.

After soldering and for the same reasons, do not try to move the capacitor's body.

8.6. ELECTROLYTES: SAFETY RULES.

Electrolytes used in EXXELIA capacitors are manufactured by EXXELIA. Main solvents are generally γ butyrolactone and ethylene glycol, very stable high boiling point solvents. Ionic conductive salts in electrolyte induce a very weak acidity (pH 5 to 7).

8.7. ENVIRONMENT.

In aluminium capacitors with liquid electrolyte there is no component showing a pollution risk, in small amounts, of air or water. EXXELIA is always involved in this security field particularly in using chemicals for electrolyte, without well-known risks.

- Dimethylformamide (DMF) dangerous solvent forbidden in several uses is completely excluded by EXXELIA, since 1990.
- There is no halogen compound such as chlorofluorocarbon (CFC or FCKW in german) or polychlorobiphenyl (PCBPyrallene) or pentabromodiphenylether or octabromodiphenylether.

There is neither benzene, toluene or phenyl compound nor explosive such as picric acid, nor asbestos in plastic covers. All the capacitors made by EXXELIA since 1991, can be scrapped or used in raw materials recycling processes without special care in compliance with Community rules.

EXXELIA aluminium capacitors with non-solid electrolyte are particularly suitable for different kinds of environment taking in account severity increasing laws.

European directives 2003/11/EC, 2002/96/EC (WEEE) and 2002/95/EC (RoHS) applies to all EXXELIA capacitors including every solder type, manufactured with pure tin coated pins or wires, since at least January 2006.

Mounting and insulating parts

STUD FIXING: FELSIC BD

Steel nut, spring washer and insulating washer are delivered loosely with the capacitor.

STANDARD MOUNTING WITH:

Insulating washer and steel nut

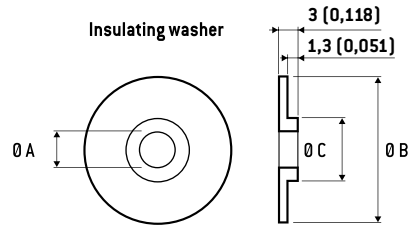
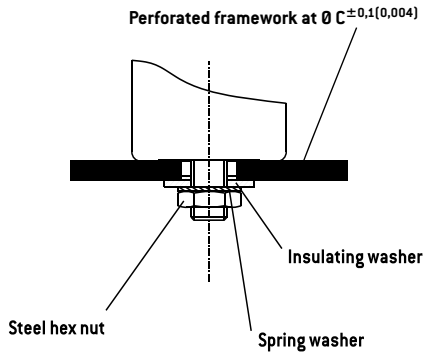

Ø Capacitor	DIMENSIONS in mm (inches)				
	M	Ø A	Ø B	Ø C	Code
36	8	8,4	25	18,5	A 691060
51 - 77	12	12,5	30	21,5	A 691061
90	12	12,5	35	21,5	A 691062

Insulating plastic nut with or without insulating washer

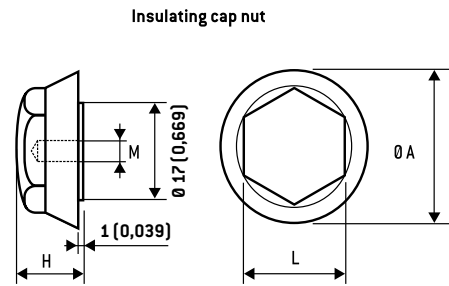
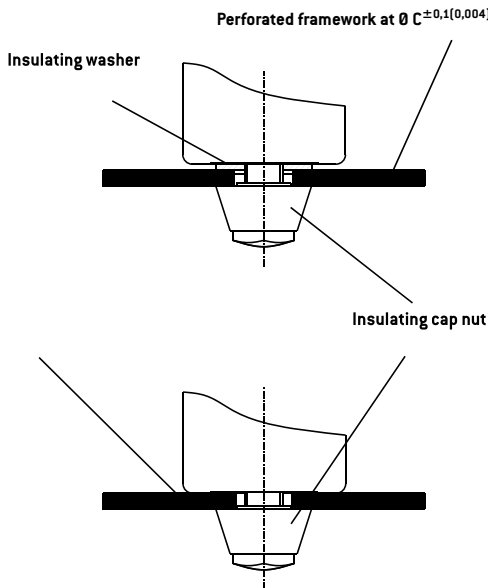

DIMENSIONS in mm (inches)					
M	Ø A	H	L	Max. torque	Code
8 (0,315)	25 (0,984)	15 (0,591)	17 (0,669)	3 Nm	A 691070
12 (0,472)	30 (1,181)	20 (0,787)	19 (0,748)	7 Nm	A 691071

Ring - clip mounting: FELSIC LP

Ring clips shall be ordered separately.

Tightening screws and nuts are supplied loosely.

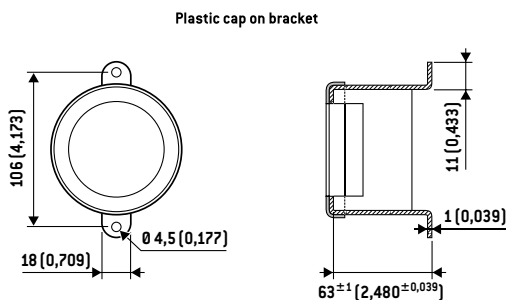

FELSIC 85 LP FELSIC 105 LP	Code
Metal bracket	A691055
Plastic cap	A691065

General technical data

Ring - clip mounting: FELSIC BC

Ring clips shall be ordered separately.

Tightening screws and nuts are supplied loosely.

FELSIC BC - Metal ring-clips

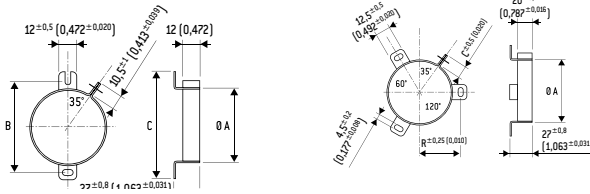

Ø A Cap.	B	C	Code	Ø A Cap.	B	C	Code
36	54	63	A 691901	51	33,5	11,8	A 691905
				66	39	10,5	A 691913
				73	44	10,5	A 691914
				77	44,5	10,5	A 691907
				90	53,3	11,8	A 691915

Stirrup mounting: CUBISIC LP

Stirrups shall be ordered separately.

Tightening screws and nuts are supplied loosely

Salt mist endurance of screws and mounting accessories:
minimum 96 h (IEC 600 68-2-11)

CUBISIC /CUBISIC LP - Metal bracket

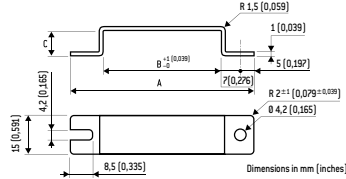

Ø A Cap.	A	B	C	Code
45x12 (1,772x0,472)	69 (2,717)	45 (1,772)	10 (0,394)	A 691057
35x16 (1,378x0,630)	59 (2,323)	35 (1,378)	14 (0,551)	A 691059

PACKAGING

1. PACKAGING AND WEIGHT UNITS.

1.1. Capacitor with screw terminals

Can DIMENSIONS in mm (inches)				Unit weight *
Ø	H			(g)
36 (1,417)	47 (1,850)	52 (2,047)	53 (2,087)	70
36 (1,417)	60 (2,362)			79
36 (1,417)	80 (3,150)	81 (3,189)		100
36 (1,417)	104 (4,094)	105 (4,134)		120
51 (2,008)	47 (1,850)			80
51 (2,008)	62 (2,441)	63 (2,480)		105
51 (2,008)	81 (3,189)	82 (3,228)		190
51 (2,008)	104 (4,094)	105 (4,134)		260
51 (2,008)	112 (4,409)			270
51 (2,008)	144 (5,669)			370
66 (2,598)	104 (4,094)	105 (4,134)		430
66 (2,598)	112 (4,409)			460
73 (2,874)	104 (4,094)	112 (4,409)		600
73 (2,874)	144 (5,669)			680
77 (3,031)	104 (4,094)	105 (4,134)		620
77 (3,031)	144 (5,669)	145 (5,709)		860
77 (3,031)	200 (7,874)			1300
77 (3,031)	220 (7,874)	221 (8,701)		1400
90 (3,543)	67 (2,638)			600
90 (3,543)	144 (5,669)	145 (5,709)		1400
90 (3,543)	200 (7,874)			1800

* Unit weight = typical values

Possible variations of = ± 25 % according to different voltage and capacitance.

1.2. Radial solder types

Can dimensions mm (inches)		ALSIC	SNAP-SIC	Can dimensions		AL-SIC	SNAP-SIC
Ø	H	Weight* (g)		Ø	H	Weight* (g)	
10 (0,394)	16 (0,630)	1,8	-	35 (1,378)	30 (1,181)	-	50
12,5 (0,492)	21 (0,827)	4,5	-	35 (1,378)	40 (1,575)	-	50
12,5 (0,492)	24 (0,945)	5	-	35 (1,378)	45 (1,772)	-	52
				35 (1,378)	50 (1,969)	-	60
16 (0,630)	25 (0,984)	8,2	-	35 (1,378)	75 (2,953)	-	95
				35 (1,378)	100 (3,937)	-	125
22 (0,866)	25 (0,984)	-	15	40 (1,575)	40 (1,575)	-	65
22 (0,866)	30 (1,181)	-	17	40 (1,575)	50 (1,969)	-	100
22 (0,866)	40 (1,575)	-	18	40 (1,575)	75 (2,953)	-	130
				40 (1,575)	100 (3,937)	-	170
25 (0,984)	25 (0,984)	-	17	45 (1,772)	21 (0,827)	-	50
25 (0,984)	30 (1,181)	-	20	45 (1,772)	30 (1,181)	-	60
25 (0,984)	35 (1,378)	-	22	45 (1,772)	35 (1,378)	-	73
25 (0,984)	40 (1,575)	-	25	45 (1,772)	45 (1,772)	-	85
25 (0,984)	45 (1,772)	-	28	45 (1,772)	45 (1,772)	-	110
25 (0,984)	50 (1,969)	-	30	45 (1,772)	75 (2,953)	-	180
				45 (1,772)	100 (3,937)	-	240
30 (1,181)	25 (0,984)	-	28				
30 (1,181)	30 (1,181)	-	30				
30 (1,181)	35 (1,378)	-	30				
30 (1,181)	40 (1,575)	-	40				
30 (1,181)	45 (1,772)	-	45				
30 (1,181)	50 (1,969)	-	50				

Can DIMENSIONS in mm (inches)			CUBISIC
I	L	H	weight (g)
35 (1,378)	35 (1,378)	16 (0,630)	30
35 (1,378)	50 (1,969)	16 (0,630)	40
45 (1,772)	35 (1,378)	12 (0,472)	30
45 (1,772)	50 (1,969)	12 (0,472)	45
45 (1,772)	75 (2,953)	12 (0,472)	60

* Unit weight = typical values

Possible variations of = ± 25 % according to different voltage and capacitance.

1.3. Axial types

Can DIMENSIONS in mm (inches)		PRORELSIC RELSIC	PRORELSIC PROMISIC	SICAL CO 42 SICAL
Ø	H	Unit weight * (g)	Unit weight * (g)	Unit weight * (g)
6,5 (0,256)	15 (0,591)	-	1,6	-
6,5 (0,256)	19 (0,748)	-	1,8	1,8
8,5 (0,335)	19 (0,748)	-	2,3	2,3
10 (0,394)	19 (0,748)	-	2,8	2,8
10 (0,394)	25 (0,984)	-	3,5	3,5
10 (0,394)	28 (1,102)	-	3,8	-
12 (0,472)	25 (0,984)	-	5	-
12 (0,472)	30 (1,181)	-	5,4	5,4
14 (0,551)	30 (1,181)	-	6,9	6,9
14 (0,551)	41 (1,614)	-	9,5	-
	30 (1,181)	7,7	-	7,7
18 (0,709)	35 (1,378)	13,6	-	-
18 (0,709)	40 (1,575)	15,3	-	15,3
21 (0,827)	40 (1,575)	19,5	-	19,5
25 (0,984)	40 (1,575)	28	-	28
25 (0,984)	50 (1,969)	35	-	35
25 (0,984)	75 (2,953)	56	-	56

* Unit weight = typical values

Possible variations of = ± 25 % according to different voltage and capacitance.

General technical data

2. PACKAGING ON TAPE

2.1. Axial types

Dimensions and tolerance in accordance with IEC 60 286-

(1) On tape only on request

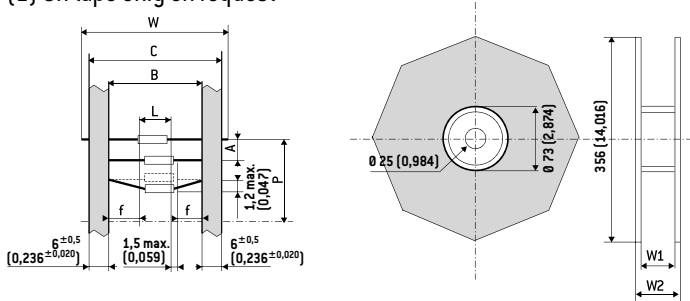

DIMENSIONS in mm (inches)									
D	L max.	B	A	P	C max.	W ₁	W ₂ max.	W	n ⁽²⁾
6,5 (0,256)	20 (0,787)	73 ^{±1,5}	10 ^{±1,5}	± 2 (0,079)	87,5 (3,445)	93 (3,661)	106 (3,661)	85 ^{±1,5}	1000 (39,370)
8,5 (0,335) ⁽¹⁾		(2,874 ^{±0,059})	(0,394 ^{±0,059})					(3,346 ^{±0,059})	750 (29,528)
10 (0,394) ⁽¹⁾	32 (1,260)	73 ^{±1,5}	15 ^{±1,5}	± 3 (0,118)	87,5 (3,445)	93 (3,661)	106 (3,661)	85 ^{±1,5}	400 (15,748)
12 (0,472) ⁽¹⁾		(2,874 ^{±0,059})	(0,591 ^{±0,059})					(3,346 ^{±0,059})	400 (15,748)
14 (0,551) ⁽¹⁾									200 (7,874)

(2) n = number of capacitors per reel.

White positive tape f: > 20 mm (0,787 inches)

P: 10 space

SNAPSIC HC

8 000 h / 85°C

25 V ... 450 V	47 µF ... 47 000 µF	Ø 22 [0,866] ... Ø 35 [1,378]	- 40°C + 85°C	Long Life Time
----------------	---------------------	-------------------------------	---------------	----------------



APPLICATIONS

- For solid PC board mounting
- Switch mode power supplies
- Impulse current

Fixing: Printed SNAP-IN pins

Tolerance on capacitance at 20°C : ± 20 %
 Operating temperature : - 40°C + 85°C

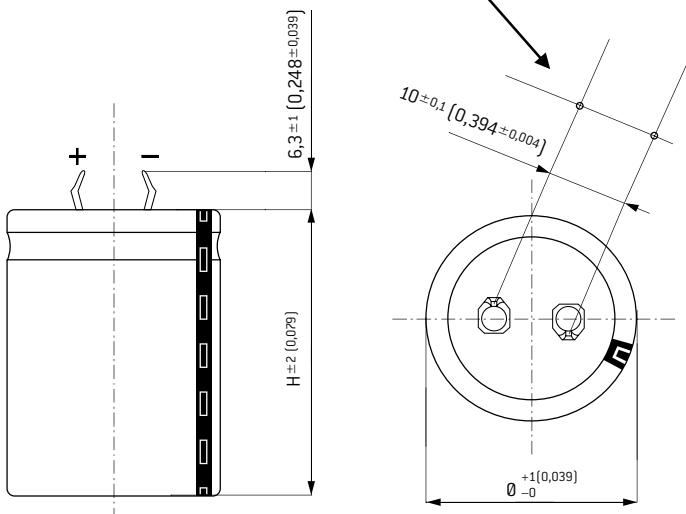
Ø PC board holes: $2 \pm 0,1$ [0,079±0,004]

Dimensions in mm (inches)

DIMENSIONS in mm (inches)

Can size	Ø	H
1	22 [0,866]	25 [0,984]
2	22 [0,866]	30 [1,181]
3	22 [0,866]	40 [1,575]
4	25 [0,984]	25 [0,984]
5	25 [0,984]	30 [1,181]
6	25 [0,984]	40 [1,575]
7*	25 [0,984]	50 [1,969]
8	30 [1,181]	25 [0,984]
9	30 [1,181]	30 [1,181]
10	30 [1,181]	35 [1,378]
11	30 [1,181]	40 [1,575]
12*	30 [1,181]	45 [1,772]
13	30 [1,181]	50 [1,969]
14	35 [1,378]	30 [1,181]
15	35 [1,378]	35 [1,378]
16	35 [1,378]	40 [1,575]
17	35 [1,378]	45 [1,772]
18	35 [1,378]	50 [1,969]

* Out of range

RESISTANCE TO VIBRATIONS

	Standard
f (Hz)	10 - 2000 Hz
Amplitude	1,5 [0,059]
Acceleration	20 g
t (h)	3 x 2 h

SPECIFICATIONS

CECC 30300 Long life
 DIN 41 240 - Climatic category and GPF: -40 +85°C / 56 days
 IEC 60 384.4 long life
 Standard endurance test at U_R : 2000 h / 85°C

WITHSTAND STRENGTH OF INSULATING SLEEVE

Insulation resistance at 20°C between pins and mounting hardware:
 100 MΩ
 Test voltage at 50 Hz 1 min. between terminals and mounting
 hardware: 2000 V
 Fire resistance: self extinguish 15 s (IEC 60 695-2-2)

8 000 h / 85°C

Capacitance (μF)	Dimensions		ESR 100 Hz +20°C max. ($\text{m}\Omega$)	$\text{Tan}\delta$ 100 Hz +20°C max. (%)	ESR 100 Hz +20°C Typic ($\text{m}\Omega$)	Z 10 kHz +20°C Typic ($\text{m}\Omega$)	II +20°C 5 min. max. (mA)	I~ 100 Hz		Code		
	\varnothing mm (inches)	H mm (inches)						+40°C max. (A)	+85°C max. (A)			
Rated voltage 25 V												
5600	22	[0,866]	25	[0,984]	205	72	135	133	0,8	3,5	2,4	A780001
7200	22	[0,866]	30	[1,181]	155	70	102	100	1,1	4,4	3	A780002
10000	22	[0,866]	35	[1,378]	117	74	76	75	1,5	5,4	3,6	A780003
12000	22	[0,866]	40	[1,575]	97	73	62	62	1,8	6,3	4,3	A780004
7200	25	[0,984]	25	[0,984]	159	72	104	103	1,1	4,3	2,8	A780005
10000	25	[0,984]	30	[1,181]	115	72	75	74	1,5	5,5	3,6	A780006
12000	25	[0,984]	35	[1,378]	96	72	62	61	1,8	6,4	4,2	A780007
15000	25	[0,984]	40	[1,575]	78	73	50	49	2,3	7,6	5	A780008
18000	25	[0,984]	45	[1,772]	65	74	41	41	2,7	8,8	5,8	A780009
22000	25	[0,984]	50	[1,969]	56	77	35	35	3,3	9,9	6,4	A780010
12000	30	[1,181]	25	[0,984]	108	81	70	69	1,8	5,8	3,5	A780011
15000	30	[1,181]	30	[1,181]	83	78	53	52	2,3	7,1	4,4	A780012
22000	30	[1,181]	35	[1,378]	62	86	40	39	3,3	8,8	5,3	A780013
27000	30	[1,181]	40	[1,575]	52	88	33	32	4,1	10,2	6,2	A780014
33000	30	[1,181]	45	[1,772]	43	90	27	27	5,0	11,9	7,1	A780015
36000	30	[1,181]	50	[1,969]	40	90	25	24	5,4	12,9	7,8	A780016
18000	35	[1,378]	25	[0,984]	86	97	55	55	2,7	7	3,9	A780017
22000	35	[1,378]	30	[1,181]	64	88	40	40	3,3	8,8	4,9	A780018
27000	35	[1,378]	35	[1,378]	52	88	32	32	4,1	10,4	5,9	A780019
36000	35	[1,378]	40	[1,575]	41	94	26	25	5,4	12,3	6,8	A780020
42000	35	[1,378]	45	[1,772]	35	92	21	21	6,3	14,2	7,9	A780021
47000	35	[1,378]	50	[1,969]	32	95	19	19	7,1	15,6	8,6	A780022
Rated voltage 35 V												
2700	22	[0,866]	25	[0,984]	201	34	132	129	0,6	3,5	2,2	A780023
3300	22	[0,866]	30	[1,181]	161	33	105	103	0,7	4,3	2,7	A780024
4700	22	[0,866]	35	[1,378]	115	34	74	73	1,0	5,4	3,4	A780025
5600	22	[0,866]	40	[1,575]	97	34	62	61	1,2	6,3	4	A780026
3600	25	[0,984]	25	[0,984]	154	35	101	99	0,8	4,3	2,6	A780027
4700	25	[0,984]	30	[1,181]	118	35	77	75	1,0	5,3	3,3	A780028
6800	25	[0,984]	35	[1,378]	88	37	57	55	1,4	6,6	4	A780029
8200	25	[0,984]	40	[1,575]	73	37	46	45	1,7	7,7	4,7	A780030
10000	25	[0,984]	45	[1,772]	60	38	38	37	2,1	9	5,5	A780031
10000	25	[0,984]	50	[1,969]	57	36	36	35	2,1	9,7	5,9	A780032
5600	30	[1,181]	25	[0,984]	112	39	72	71	1,2	5,6	3,1	A780033
8000	30	[1,181]	30	[1,181]	81	41	52	51	1,7	7	3,9	A780034
10000	30	[1,181]	35	[1,378]	64	40	41	40	2,1	8,5	4,7	A780035
12000	30	[1,181]	40	[1,575]	53	40	34	33	2,5	9,9	5,5	A780036
15000	30	[1,181]	45	[1,772]	45	42	28	27	3,2	11,4	6,4	A780037
15000	30	[1,181]	50	[1,969]	43	40	26	26	3,2	12,3	7	A780038
8200	35	[1,378]	25	[0,984]	93	48	60	59	1,7	6,5	3,3	A780039
11000	35	[1,378]	30	[1,181]	68	47	43	43	2,3	8,2	4,2	A780040
14000	35	[1,378]	35	[1,378]	54	47	34	33	2,9	9,9	5,1	A780041
17000	35	[1,378]	40	[1,575]	45	48	28	27	3,6	11,5	5,9	A780042
21000	35	[1,378]	45	[1,772]	37	49	23	23	4,4	13,3	6,8	A780043
21000	35	[1,378]	45	[1,772]	37	49	23	23	4,4	13,3	6,8	A780044
22000	35	[1,378]	50	[1,969]	35	48	21	21	4,6	14,5	7,5	A780045
Rated voltage 40 V												
3600	22	[0,866]	25	[0,984]	197	45	130	127	0,9	3,6	2,3	A780046
4700	22	[0,866]	30	[1,181]	144	42	94	92	1,1	4,5	2,9	A780047
6200	22	[0,866]	35	[1,378]	113	44	73	72	1,5	5,5	3,5	A780048
8200	22	[0,866]	40	[1,575]	93	48	60	59	2,0	6,4	4,1	A780049
4700	25	[0,984]	25	[0,984]	151	44	98	97	1,1	4,4	2,7	A780050
6800	25	[0,984]	30	[1,181]	110	47	71	70	1,6	5,5	3,4	A780051
6800	25	[0,984]	30	[1,181]	110	47	71	70	1,6	5,5	3,4	A780052
8200	25	[0,984]	35	[1,378]	87	45	56	55	2,0	6,7	4,1	A780053
10000	25	[0,984]	40	[1,575]	72	45	46	45	2,4	7,8	4,8	A780054
12000	25	[0,984]	45	[1,772]	60	45	38	37	2,9	9	5,6	A780055
15000	25	[0,984]	50	[1,969]	103	97	67	66	3,6	6,5	4,4	A780056
8200	30	[1,181]	25	[0,984]	202	104	132	131	2,0	3,8	2,4	A780057
10000	30	[1,181]	30	[1,181]	80	50	52	51	2,4	7,1	4	A780058
12000	30	[1,181]	35	[1,378]	66	49	42	41	2,9	8,4	4,8	A780059
15000	30	[1,181]	40	[1,575]	54	50	34	33	3,6	9,9	5,6	A780060
20000	30	[1,181]	45	[1,772]	44	55	27	27	4,8	11,5	6,5	A780061
22000	30	[1,181]	50	[1,969]	41	56	25	25	5,3	12,6	7,1	A780062
10000	35	[1,378]	25	[0,984]	92	58	59	59	2,4	6,6	3,4	A780063
15000	35	[1,378]	30	[1,181]	67	63	43	42	3,6	8,3	4,3	A780064
18000	35	[1,378]	35	[1,378]	53	60	34	33	4,3	10	5,1	A780065
22000	35	[1,378]	40	[1,575]	44	61	28	27	5,3	11,6	6	A780066
27000	35	[1,378]	45	[1,772]	37	63	23	22	6,5	13,4	6,9	A780067
33000	35	[1,378]	50	[1,969]	56	71	21	35	7,9	10,7	6,2	A780068

SNAPSIC HC

8 000 h / 85°C

Capacitance (μF)	Dimensions		ESR 100 Hz +20°C max. ($\text{m}\Omega$)	Tan δ 100 Hz +20°C max. (%)	ESR 100 Hz +20°C Typic ($\text{m}\Omega$)	Z 10 kHz +20°C Typic ($\text{m}\Omega$)	II +20°C 5 min. max. (mA)	I~ 100 Hz		Code		
	\varnothing mm (inches)	H mm (inches)						+40°C max. (A)	+85°C max. (A)			
Rated voltage 50 V												
1800	22	(0,866)	25	(0,866)	216	24	142	138	0,5	3,4	2,1	A780069
2000	22	(0,866)	25	(0,866)	202	25	133	129	0,6	3,5	2,2	A780070
2700	22	(0,866)	30	(0,866)	147	25	96	93	0,8	4,4	2,7	A780071
3600	22	(0,866)	35	(0,866)	116	26	75	73	1,1	5,4	3,3	A780072
4200	22	(0,866)	40	(0,866)	96	25	62	60	1,3	6,3	3,9	A780073
2700	25	(0,984)	25	(0,984)	154	26	101	98	0,8	4,3	2,6	A780074
3600	25	(0,984)	30	(0,984)	114	26	74	72	1,1	5,4	3,2	A780075
4700	25	(0,984)	35	(0,984)	89	26	57	55	1,4	6,6	3,9	A780076
5600	25	(0,984)	40	(0,984)	74	26	48	46	1,7	7,6	4,5	A780077
6800	25	(0,984)	45	(0,984)	62	26	39	38	2,0	8,8	5,3	A780078
8200	25	(0,984)	50	(0,984)	56	29	35	34	2,5	9,7	5,8	A780079
4200	30	(1,181)	25	(1,181)	113	30	73	71	1,3	5,5	3	A780080
5600	30	(1,181)	30	(1,181)	82	29	53	52	1,7	7	3,8	A780081
6800	30	(1,181)	35	(1,181)	67	29	43	42	2,0	8,3	4,6	A780082
6800	30	(1,181)	35	(1,181)	67	29	43	42	2,0	8,3	4,6	A780083
8200	30	(1,181)	40	(1,181)	56	29	35	34	2,5	9,6	5,3	A780084
10000	30	(1,181)	45	(1,181)	47	29	29	28	3,0	11,1	6,2	A780085
12000	30	(1,181)	50	(1,181)	42	31	26	25	3,6	12,4	6,8	A780086
5600	35	(1,378)	25	(1,378)	95	33	61	60	1,7	6,5	3,3	A780087
8200	35	(1,378)	30	(1,378)	69	35	44	43	2,5	8,2	4,1	A780088
10000	35	(1,378)	35	(1,378)	55	34	35	34	3,0	9,8	5	A780089
12000	35	(1,378)	40	(1,378)	46	35	29	28	3,6	11,4	5,8	A780090
15000	35	(1,378)	45	(1,378)	38	36	23	23	4,5	13,2	6,7	A780091
16000	35	(1,378)	50	(1,378)	35	35	22	21	4,8	14,4	7,3	A780092
Rated voltage 63 V												
1200	22	(0,866)	25	(0,984)	239	18	158	151	0,5	3,2	1,9	A780093
1800	22	(0,866)	30	(1,181)	161	18	106	101	0,7	4,2	2,5	A780094
2200	22	(0,866)	35	(1,378)	132	18	86	82	0,8	5	3	A780095
2700	22	(0,866)	40	(1,575)	108	18	70	67	1,0	5,8	3,5	A780096
1800	25	(0,984)	25	(0,984)	167	19	109	105	0,7	4,1	2,4	A780097
2400	25	(0,984)	30	(1,181)	125	19	82	78	0,9	5,1	3	A780098
3100	25	(0,984)	35	(1,378)	98	19	63	61	1,2	6,2	3,6	A780099
3600	25	(0,984)	40	(1,575)	84	19	54	52	1,4	7,1	4,2	A780100
4700	25	(0,984)	45	(1,772)	66	19	42	40	1,8	8,5	5	A780101
4700	25	(0,984)	50	(1,969)	65	19	41	40	1,8	8,9	5,3	A780102
2700	30	(1,181)	25	(0,984)	122	21	80	77	1,0	5,3	2,9	A780103
3700	30	(1,181)	30	(1,181)	90	21	58	56	1,4	6,6	3,7	A780104
4700	30	(1,181)	35	(1,378)	71	21	45	44	1,8	8	4,4	A780105
5600	30	(1,181)	40	(1,575)	60	21	38	36	2,1	9,2	5,1	A780106
6800	30	(1,181)	45	(1,772)	50	21	31	30	2,6	10,7	5,9	A780107
8200	30	(1,181)	50	(1,969)	43	22	27	26	3,1	12	6,5	A780108
3700	35	(1,378)	25	(0,984)	101	24	66	63	1,4	6,3	3,2	A780109
5200	35	(1,378)	30	(1,181)	74	24	47	45	2,0	7,9	4	A780110
6800	35	(1,378)	35	(1,378)	58	25	36	35	2,6	9,5	4,9	A780111
8200	35	(1,378)	40	(1,575)	48	25	30	29	3,1	11,1	5,7	A780112
10000	35	(1,378)	45	(1,772)	40	25	25	24	3,8	12,8	6,5	A780113
11000	35	(1,378)	50	(1,969)	37	25	23	22	4,2	14	7,1	A780114
Rated voltage 80 V												
1200	22	(0,866)	25	(0,984)	224	17	147	140	0,6	3,3	1,9	A780115
1500	22	(0,866)	30	(1,181)	163	15	107	102	0,7	4,2	2,5	A780116
2000	22	(0,866)	35	(1,378)	128	16	83	79	1,0	5	3	A780117
2700	22	(0,866)	40	(1,575)	193	33	127	124	1,3	4,4	2,9	A780118
1500	25	(0,984)	25	(0,984)	170	16	111	106	0,7	4	2,3	A780119
2200	25	(0,984)	30	(1,181)	124	17	80	77	1,1	5,1	3	A780120
2700	25	(0,984)	35	(1,378)	97	17	63	60	1,3	6,2	3,6	A780121
3300	25	(0,984)	40	(1,575)	81	17	52	49	1,6	7,2	4,2	A780122
4200	25	(0,984)	45	(1,772)	67	18	43	41	2,0	8,4	4,8	A780123
4200	25	(0,984)	50	(1,969)	62	16	39	38	2,0	9,1	5,3	A780124
2200	30	(1,181)	25	(0,984)	126	17	82	78	1,1	5,2	2,8	A780125
3300	30	(1,181)	30	(1,181)	89	18	58	55	1,6	6,6	3,6	A780126
4200	30	(1,181)	35	(1,378)	71	19	45	43	2,0	8	4,3	A780127
5200	30	(1,181)	40	(1,575)	58	19	37	35	2,5	9,3	5	A780128
6200	30	(1,181)	45	(1,772)	49	19	30	29	3,0	10,8	5,8	A780129
6800	30	(1,181)	50	(1,969)	45	19	28	27	3,3	11,8	6,4	A780130
3300	35	(1,378)	25	(0,984)	100	21	65	62	1,6	6,2	3,2	A780131
4700	35	(1,378)	30	(1,181)	73	22	47	45	2,3	7,9	4	A780132
6000	35	(1,378)	35	(1,378)	58	22	37	35	2,9	9,5	4,8	A780133
7200	35	(1,378)	40	(1,575)	48	22	30	29	3,5	11	5,6	A780134
9000	35	(1,378)	45	(1,772)	40	23	25	24	4,3	12,8	6,4	A780135
10000	35	(1,378)	50	(1,969)	37	23	23	22	4,8	13,9	7	A780136

8 000 h / 85°C

Capacitance (μF)	Dimensions		ESR 100 Hz +20°C max. ($\text{m}\Omega$)	Tan δ 100 Hz +20°C max. (%)	ESR 100 Hz +20°C Typic ($\text{m}\Omega$)	Z 10 kHz +20°C Typic ($\text{m}\Omega$)	I +20°C 5 min. max. (mA)	I \sim 100 Hz		Code		
	\varnothing mm (inches)	H mm (inches)						+40°C max. (A)	+85°C max. (A)			
Rated voltage 100 V												
680	22	(0,866)	25	(0,984)	240	10	158	146	0,4	3,1	1,7	A780137
680	22	(0,866)	25	(0,984)	237	10	156	144	0,4	3,1	1,8	A780138
900	22	(0,866)	30	(1,181)	179	10	117	108	0,5	3,9	2,2	A780139
1200	22	(0,866)	35	(1,378)	135	10	88	82	0,7	4,8	2,7	A780140
1500	22	(0,866)	40	(1,575)	111	10	72	67	0,9	5,6	3,2	A780141
900	25	(0,984)	25	(0,984)	185	10	121	112	0,5	3,8	2,1	A780142
1200	25	(0,984)	30	(1,181)	139	10	90	84	0,7	4,8	2,6	A780143
1700	25	(0,984)	35	(1,378)	103	11	66	62	1,0	5,9	3,3	A780144
2100	25	(0,984)	40	(1,575)	85	11	55	51	1,3	6,9	3,8	A780145
2500	25	(0,984)	45	(1,772)	70	11	45	42	1,5	8,0	4,4	A780146
2700	25	(0,984)	50	(1,969)	65	11	41	38	1,6	8,8	4,8	A780147
1500	30	(1,181)	25	(0,984)	129	12	84	78	0,9	5,0	2,6	A780148
2000	30	(1,181)	30	(1,181)	94	12	61	57	1,2	6,4	3,3	A780149
2500	30	(1,181)	35	(1,378)	75	12	48	45	1,5	7,6	4,0	A780150
3100	30	(1,181)	40	(1,575)	61	12	39	36	1,9	8,9	4,7	A780151
3700	30	(1,181)	45	(1,772)	51	12	32	30	2,2	10,3	5,4	A780152
4000	30	(1,181)	50	(1,969)	48	12	30	28	2,4	11,2	5,9	A780153
2000	35	(1,378)	25	(0,984)	106	13	69	65	1,2	6,0	3,0	A780154
2800	35	(1,378)	30	(1,181)	77	14	49	47	1,7	7,6	3,7	A780155
3600	35	(1,378)	35	(1,378)	61	14	39	36	2,2	9,1	4,5	A780156
4700	35	(1,378)	40	(1,575)	51	15	32	30	2,8	10,6	5,2	A780157
5200	35	(1,378)	45	(1,772)	43	14	26	25	3,1	12,2	6,0	A780158
3800	35	(1,378)	50	(1,969)	49	12	31	29	3,4	12,1	6,4	A780159
5700	35	(1,378)	50	(1,969)	39	14	24	23	3,4	13,4	6,6	A780160
Rated voltage 160 V												
300	22	(0,866)	25	(0,984)	309	6	204	177	0,3	2,6	1,4	A780161
420	22	(0,866)	30	(1,181)	224	6	147	128	0,4	3,4	1,7	A780162
540	22	(0,866)	35	(1,378)	176	6	115	100	0,5	4,1	2,1	A780163
670	22	(0,866)	40	(1,575)	145	6	95	82	0,6	4,7	2,4	A780164
420	25	(0,984)	25	(0,984)	232	6	153	133	0,4	3,3	1,7	A780165
570	25	(0,984)	30	(1,181)	169	6	110	96	0,6	4,2	2,1	A780166
730	25	(0,984)	35	(1,378)	133	6	86	75	0,7	5	2,5	A780167
890	25	(0,984)	40	(1,575)	109	6	71	62	0,9	5,9	3	A780168
1100	25	(0,984)	45	(1,772)	91	6	58	51	1,1	6,8	3,4	A780169
1200	25	(0,984)	50	(1,969)	84	6	54	47	1,2	7,4	3,8	A780170
680	30	(1,181)	25	(0,984)	250	11	164	153	0,7	3,6	2	A780171
870	30	(1,181)	30	(1,181)	119	7	77	68	0,8	5,5	2,7	A780172
1200	30	(1,181)	35	(1,378)	142	11	93	86	1,2	5,5	3	A780173
1500	30	(1,181)	40	(1,575)	117	11	76	71	1,4	6,5	3,5	A780174
1700	30	(1,181)	45	(1,772)	64	7	41	36	1,6	8,9	4,4	A780175
1800	30	(1,181)	50	(1,969)	59	7	38	33	1,7	9,8	4,8	A780176
820	35	(1,378)	25	(0,984)	132	7	86	76	0,8	5,3	2,5	A780177
1200	35	(1,378)	30	(1,181)	95	7	61	54	1,2	6,7	3,2	A780178
1500	35	(1,378)	35	(1,378)	75	7	48	43	1,4	8	3,8	A780179
2000	35	(1,378)	40	(1,575)	62	8	39	35	1,9	9,4	4,5	A780180
2500	35	(1,378)	45	(1,772)	75	12	48	45	2,4	9,2	4,8	A780181
2700	35	(1,378)	50	(1,969)	48	8	30	26	2,6	11,8	5,6	A780182
Rated voltage 200 V												
250	22	(0,866)	25	(0,984)	339	5	224	191	0,3	2,5	1,2	A780183
360	22	(0,866)	30	(1,181)	246	6	162	138	0,4	3,2	1,6	A780184
460	22	(0,866)	35	(1,378)	193	6	127	108	0,6	3,8	1,9	A780185
570	22	(0,866)	40	(1,575)	159	6	104	89	0,7	4,5	2,2	A780186
350	25	(0,984)	25	(0,984)	257	6	169	145	0,4	3,1	1,5	A780187
470	25	(0,984)	30	(1,181)	186	5	122	105	0,6	3,9	1,9	A780188
620	25	(0,984)	35	(1,378)	146	6	96	82	0,7	4,7	2,3	A780189
760	25	(0,984)	40	(1,575)	121	6	79	67	0,9	5,5	2,7	A780190
920	25	(0,984)	45	(1,772)	100	6	65	55	1,1	6,4	3,2	A780191
1000	25	(0,984)	50	(1,969)	92	6	59	51	1,2	7	3,5	A780192
540	30	(1,181)	25	(0,984)	184	6	120	105	0,7	4	1,9	A780193
680	30	(1,181)	30	(1,181)	134	6	87	76	0,8	5,1	2,5	A780194
1000	30	(1,181)	35	(1,378)	153	10	100	92	1,2	5,3	2,8	A780195
1200	30	(1,181)	40	(1,575)	127	10	82	76	1,4	6,2	3,2	A780196
1400	30	(1,181)	45	(1,772)	72	6	46	40	1,7	8,3	4	A780197
1500	30	(1,181)	50	(1,969)	66	6	42	37	1,8	9,1	4,4	A780198
760	35	(1,378)	25	(0,984)	149	7	97	86	0,9	4,9	2,3	A780199
1000	35	(1,378)	30	(1,181)	109	7	70	62	1,2	6,2	2,9	A780200
1400	35	(1,378)	35	(1,378)	121	11	79	73	1,7	6,4	3,2	A780201
1600	35	(1,378)	40	(1,575)	71	7	45	40	1,9	8,6	4	A780202
2000	35	(1,378)	45	(1,772)	59	7	37	33	2,4	10	4,6	A780203
2200	35	(1,378)	50	(1,969)	54	8	34	30	2,6	10,9	5	A780204

SNAPSIC HC

8 000 h / 85°C

Capacitance (μF)	Dimensions		ESR 100 Hz +20°C max. ($\text{m}\Omega$)	Tan δ 100 Hz +20°C max. (%)	ESR 100 Hz +20°C Typic ($\text{m}\Omega$)	Z 10 kHz +20°C Typic ($\text{m}\Omega$)	I +20°C 5 min. max. (mA)	I \sim 100 Hz		Code		
	\varnothing mm (inches)	H mm (inches)						+40°C max. (A)	+85°C max. (A)			
Rated voltage 250 V												
190	22	(0,866)	25	(0,984)	385	5	255	211	0,3	2,3	1,1	A780205
270	22	(0,866)	30	(1,181)	279	5	184	153	0,4	2,9	1,4	A780206
330	22	(0,866)	35	(1,378)	219	5	144	119	0,5	3,5	1,7	A780207
420	22	(0,866)	40	(1,575)	180	5	118	98	0,6	4,1	2	A780208
250	25	(0,984)	25	(0,984)	290	5	192	160	0,4	2,9	1,4	A780209
370	25	(0,984)	30	(1,181)	211	5	138	115	0,6	3,6	1,8	A780210
470	25	(0,984)	35	(1,378)	165	5	108	90	0,7	4,4	2,1	A780211
560	25	(0,984)	40	(1,575)	136	5	89	74	0,8	5,1	2,5	A780212
680	25	(0,984)	45	(1,772)	113	5	73	61	1	5,9	2,9	A780213
740	25	(0,984)	50	(1,969)	104	5	67	56	1,1	6,5	3,1	A780214
400	30	(1,181)	25	(0,984)	206	5	135	114	0,6	3,8	1,8	A780215
520	30	(1,181)	30	(1,181)	149	5	98	83	0,8	4,8	2,3	A780216
720	30	(1,181)	35	(1,378)	118	5	76	65	1,1	5,8	2,7	A780217
820	30	(1,181)	40	(1,575)	97	5	63	53	1,2	6,7	3,2	A780218
1100	30	(1,181)	45	(1,772)	81	6	52	44	1,7	7,8	3,7	A780219
1200	30	(1,181)	50	(1,969)	74	6	47	40	1,8	8,5	4	A780220
560	35	(1,378)	25	(0,984)	165	6	108	93	0,8	4,6	2,1	A780221
770	35	(1,378)	30	(1,181)	120	6	78	67	1,2	5,8	2,7	A780222
1100	35	(1,378)	35	(1,378)	94	7	61	53	1,7	7	3,2	A780223
1200	35	(1,378)	40	(1,575)	78	6	50	43	1,8	8,1	3,7	A780224
1500	35	(1,378)	45	(1,772)	65	6	41	36	2,3	9,4	4,3	A780225
1700	35	(1,378)	50	(1,969)	60	6	38	33	2,6	10,3	4,7	A780226
Rated voltage 300 V												
150	22	(0,866)	25	(0,984)	1203	11	800	748	0,3	1,4	0,9	A780227
220	22	(0,866)	30	(1,181)	822	11	546	511	0,4	1,8	1,1	A780228
270	22	(0,866)	35	(1,378)	670	11	445	416	0,5	2,2	1,3	A780229
330	22	(0,866)	40	(1,575)	549	11	364	340	0,6	2,5	1,6	A780230
180	25	(0,984)	25	(0,984)	1007	11	670	626	0,3	1,7	1	A780231
270	25	(0,984)	30	(1,181)	674	11	447	419	0,5	2,2	1,3	A780232
360	25	(0,984)	35	(1,378)	507	11	336	314	0,7	2,7	1,6	A780233
470	25	(0,984)	40	(1,575)	390	12	258	242	0,9	3,2	2	A780234
560	25	(0,984)	45	(1,772)	328	12	216	203	1	3,7	2,2	A780235
630	25	(0,984)	50	(1,969)	292	12	193	180	1,1	4,1	2,5	A780236
330	30	(1,181)	25	(0,984)	569	12	378	354	0,6	2,4	1,4	A780237
470	30	(1,181)	30	(1,181)	402	12	266	249	0,9	3,1	1,8	A780238
560	30	(1,181)	35	(1,378)	336	12	222	208	1	3,6	2,2	A780239
680	30	(1,181)	40	(1,575)	277	12	183	171	1,2	4,3	2,5	A780240
820	30	(1,181)	45	(1,772)	230	12	151	142	1,5	4,9	2,9	A780241
900	30	(1,181)	50	(1,969)	210	12	138	129	1,6	5,4	3,2	A780242
470	35	(1,378)	25	(0,984)	420	12	278	261	0,9	3,1	1,8	A780243
620	35	(1,378)	30	(1,181)	316	12	209	196	1,1	3,8	2,2	A780244
820	35	(1,378)	35	(1,378)	241	12	159	149	1,5	4,7	2,7	A780245
1000	35	(1,378)	40	(1,575)	198	12	130	123	1,8	5,5	3,1	A780246
1200	35	(1,378)	45	(1,772)	166	12	108	102	2,2	6,3	3,6	A780247
1300	35	(1,378)	50	(1,969)	153	12	100	94	2,3	6,8	3,9	A780248
Rated voltage 350 V												
120	22	(0,866)	25	(0,984)	1166	9	775	710	0,3	1,4	0,8	A780249
150	22	(0,866)	30	(1,181)	918	9	610	558	0,3	1,7	1	A780250
220	22	(0,866)	35	(1,378)	660	9	438	401	0,5	2,2	1,3	A780251
270	22	(0,866)	40	(1,575)	543	9	360	330	0,6	2,5	1,5	A780252
150	25	(0,984)	25	(0,984)	926	9	616	564	0,3	1,7	1	A780253
220	25	(0,984)	30	(1,181)	634	9	421	385	0,5	2,2	1,3	A780254
290	25	(0,984)	35	(1,378)	490	9	325	298	0,6	2,7	1,5	A780255
350	25	(0,984)	40	(1,575)	403	9	267	244	0,7	3,1	1,8	A780256
420	25	(0,984)	45	(1,772)	334	9	220	202	0,9	3,6	2,1	A780257
470	25	(0,984)	50	(1,969)	306	9	202	185	1	4	2,3	A780258
230	30	(1,181)	25	(0,984)	620	9	411	378	0,5	2,3	1,3	A780259
330	30	(1,181)	30	(1,181)	434	9	288	264	0,7	3	1,7	A780260
470	30	(1,181)	35	(1,378)	331	10	219	201	1	3,6	2	A780261
560	30	(1,181)	40	(1,575)	273	10	180	165	1,2	4,2	2,4	A780262
640	30	(1,181)	45	(1,772)	226	9	149	137	1,3	4,9	2,8	A780263
680	30	(1,181)	50	(1,969)	212	9	140	128	1,4	5,3	3	A780264
330	35	(1,378)	25	(0,984)	452	9	300	276	0,7	3	1,6	A780265
470	35	(1,378)	30	(1,181)	320	9	211	195	1	3,8	2,1	A780266
680	35	(1,378)	35	(1,378)	247	11	162	150	1,4	4,6	2,5	A780267
680	35	(1,378)	40	(1,575)	220	9	144	133	1,4	5,1	2,8	A780268
820	35	(1,378)	45	(1,772)	182	9	120	110	1,7	5,9	3,3	A780269
1000	35	(1,378)	50	(1,969)	154	10	101	93	2,1	6,7	3,7	A780270

8 000 h / 85°C

Capacitance (μF)	Dimensions		ESR 100 Hz +20°C max. ($\text{m}\Omega$)	Tan δ 100 Hz +20°C max. (%)	ESR 100 Hz +20°C Typic ($\text{m}\Omega$)	Z 10 kHz +20°C Typic ($\text{m}\Omega$)	II +20°C 5 min. max. (mA)	I~ 100 Hz		Code		
	\emptyset mm (inches)	H mm (inches)						+40°C max. (A)	+85°C max. (A)			
Rated voltage 400 V												
100	22	(0,866)	25	(0,984)	1334	8	887	810	0,2	1,3	0,8	A780271
150	22	(0,866)	30	(1,181)	892	8	592	541	0,4	1,7	1	A780272
200	22	(0,866)	35	(1,378)	689	9	457	417	0,5	2,1	1,2	A780273
220	22	(0,866)	40	(1,575)	608	8	403	368	0,5	2,4	1,4	A780274
150	25	(0,984)	25	(0,984)	901	8	599	547	0,4	1,7	1	A780275
200	25	(0,984)	30	(1,181)	675	8	448	409	0,5	2,1	1,2	A780276
270	25	(0,984)	35	(1,378)	511	9	338	309	0,7	2,6	1,5	A780277
330	25	(0,984)	40	(1,575)	420	9	278	254	0,8	3,1	1,8	A780278
400	25	(0,984)	45	(1,772)	346	9	229	209	1	3,6	2	A780279
440	25	(0,984)	50	(1,969)	319	9	210	192	1,1	3,9	2,2	A780280
220	30	(1,181)	25	(0,984)	628	9	417	382	0,5	2,3	1,3	A780281
330	30	(1,181)	30	(1,181)	439	9	291	266	0,8	2,9	1,7	A780282
410	30	(1,181)	35	(1,378)	344	9	228	208	1	3,5	2	A780283
500	30	(1,181)	40	(1,575)	283	9	187	171	1,2	4,1	2,3	A780284
620	30	(1,181)	45	(1,772)	234	9	154	141	1,5	4,8	2,7	A780285
680	30	(1,181)	50	(1,969)	215	9	141	130	1,6	5,2	2,9	A780286
330	35	(1,378)	25	(0,984)	450	9	298	274	0,8	3	1,6	A780287
440	35	(1,378)	30	(1,181)	330	9	218	200	1,1	3,7	2	A780288
580	35	(1,378)	35	(1,378)	256	9	168	155	1,4	4,5	2,5	A780289
680	35	(1,378)	40	(1,575)	214	9	141	129	1,6	5,2	2,8	A780290
820	35	(1,378)	45	(1,772)	178	9	117	107	2	6	3,3	A780291
1000	35	(1,378)	50	(1,969)	160	10	105	96	2,4	6,6	3,6	A780292
Rated voltage 450 V												
47	22	(0,866)	25	(0,984)	2435	7	1621	1456	0,1	1	0,5	A780293
66	22	(0,866)	25	(0,984)	1739	7	1158	1040	0,2	1,1	0,6	A780294
100	22	(0,866)	25	(0,984)	1287	8	856	770	0,3	1,3	0,7	A780295
120	22	(0,866)	30	(1,181)	962	7	639	575	0,3	1,7	0,9	A780296
150	22	(0,866)	35	(1,378)	770	7	511	460	0,4	2	1,1	A780297
220	22	(0,866)	40	(1,575)	599	8	398	357	0,6	2,4	1,3	A780298
120	25	(0,984)	25	(0,984)	970	7	645	580	0,3	1,6	0,9	A780299
160	25	(0,984)	30	(1,181)	727	7	483	434	0,4	2	1,1	A780300
220	25	(0,984)	35	(1,378)	540	7	358	322	0,6	2,5	1,4	A780301
270	25	(0,984)	40	(1,575)	444	8	294	265	0,7	3	1,7	A780302
330	25	(0,984)	45	(1,772)	366	8	242	218	0,9	3,4	1,9	A780303
330	25	(0,984)	50	(1,969)	354	7	234	211	0,9	3,7	2	A780304
180	30	(1,181)	25	(0,984)	662	7	439	396	0,5	2,2	1,2	A780305
270	30	(1,181)	30	(1,181)	464	8	307	277	0,7	2,8	1,6	A780306
330	30	(1,181)	35	(1,378)	364	8	241	217	0,9	3,4	1,9	A780307
420	30	(1,181)	40	(1,575)	299	8	198	178	1,1	4	2,2	A780308
470	30	(1,181)	45	(1,772)	255	8	168	152	1,3	4,6	2,5	A780309
560	30	(1,181)	50	(1,969)	227	8	150	135	1,5	5,1	2,8	A780310
250	35	(1,378)	25	(0,984)	495	8	328	297	0,7	2,8	1,5	A780311
330	35	(1,378)	30	(1,181)	373	8	247	223	0,9	3,5	1,9	A780312
470	35	(1,378)	35	(1,378)	269	8	177	161	1,3	4,3	2,3	A780313
560	35	(1,378)	40	(1,575)	224	8	147	133	1,5	5	2,7	A780314
680	35	(1,378)	45	(1,772)	185	8	121	110	1,8	5,8	3,1	A780315
760	35	(1,378)	50	(1,969)	168	8	110	100	2,1	6,4	3,4	A780316

SNAPSIC HC

8 000 h / 85°C

EXPECTED LIFE

as a function of temperature and ripple current:

PERMISSIBLE RIPPLE CURRENT I (R.M.S. VALUE)

versus frequency f:

I ~: permissible r.m.s. current at 100 Hz

f (Hz)	50	100	300	600	1 000	10 000	≥ 50 000
I	0,8 x I~	I~	1,2 x I~	1,3 x I~	1,35 x I~	1,5 x I~	1,6 x I~

