

SNAPSIC 105 LP

8 000 h / 105°C

| | | | | |
|----------------|-----------------------|--------------|----------------|----------------|
| 16 V ... 500 V | 330 µF ... 150 000 µF | Ø 45 (1,772) | - 55°C + 105°C | Long Life Time |
|----------------|-----------------------|--------------|----------------|----------------|



APPLICATIONS

- Printed circuit mounting
- Switch mode power supplies
- Impulse current

Fixing: SNAP-IN pins

Tolerance on capacitance at 20°C : ± 20 %
 Operating temperature : - 55°C + 105°C

Low profile lle 4 SNAP-IN terminals

Ø PC board holes: $2 \pm 0,1$
 (0,079 ± 0,004)

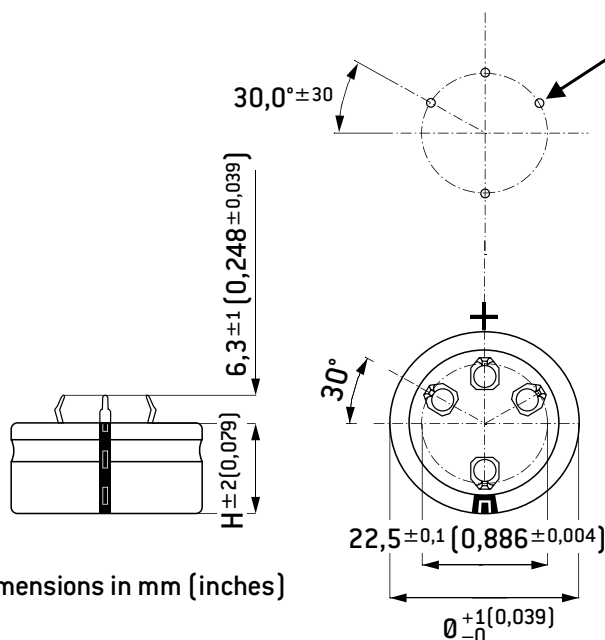

Dimensions in mm (inches)

| Can size | Ø mm (inches) | Hb mm (inches) |
|----------|---------------|----------------|
| 1* | 45 (1,772) | 16 (0,630) |
| 2 | 45 (1,772) | 21 (0,827) |
| 3 | 45 (1,772) | 25 (0,984) |
| 4 | 45 (1,772) | 30 (1,181) |
| 5 | 45 (1,772) | 35 (1,378) |
| 6 | 45 (1,772) | 40 (1,575) |

* Out of range

Dummy pins near positive terminal are for mechanical support only. They must be electrically insulated from the positive and the negative terminals.

SPECIFICATIONS

CECC 30 300 Long life
 DIN 41 240 - Climatic category: -55 + 105°C / 56 days
 IEC 60 384.4 long life
 Standard endurance test at U_R : 2000 h 105°C / 56 days

RESISTANCE TO VIBRATIONS

Frequency range 10 - 500 Hz
 Displacement amplitude 0,75 (0,030)
 or max acceleration 10 g - 98 m/s²
 Duration 3 x 2 hours

WITHSTAND STRENGTH OF INSULATING SLEEVE

Insulation resistance at 20°C between pins and mounting hardware: 100 MΩ
 Test voltage at 50 Hz 1 min. between terminals and mounting hardware: 2000 V
 Fire resistance: self extinguish 15 s (IEC 60 695-2-2)

SNAPSIC 105 LP

8 000 h / 105°C

| Capacitance (μF) | Dimensions | | Can size | Tan δ 100 Hz +20°C max. (%) | ESR 100 Hz +20°C Typic ($\text{m}\Omega$) | Z 10 kHz +20°C Typic ($\text{m}\Omega$) | II +20°C 5 min. max. (mA) | I~ 100 Hz | | Code | | |
|--|------------------------------|------------------|----------|--|--|--|---------------------------------------|----------------------|-----------------------|------|-----|----------|
| | \varnothing mm (inches) | H mm (inches) | | | | | | +40°C max. (A) | +105°C max. (A) | | | |
| Rated voltage / Peak voltage: 16/18 V | | | | | | | | | | | | |
| 22000 | 45 | (1,772) | 21 | (0,827) | 2 | 117 | 65 | 48 | 2.1 | 14 | 3.7 | A 713020 |
| 33000 | 45 | (1,772) | 25 | (0,984) | 3 | 135 | 50 | 38 | 3.0 | 17 | 4.5 | A 713021 |
| 47000 | 45 | (1,772) | 30 | (1,181) | 4 | 135 | 35 | 26 | 4.5 | 20 | 5.8 | A 713022 |
| 68000 | 45 | (1,772) | 35 | (1,378) | 5 | 140 | 25 | 19 | 6.8 | 20 | 7.2 | A 713023 |
| Rated voltage / Peak voltage: 25/29 V | | | | | | | | | | | | |
| 15000 | 45 | (1,772) | 21 | (0,827) | 2 | 80 | 65 | 50 | 2.2 | 14 | 3.7 | A 713040 |
| 22000 | 45 | (1,772) | 25 | (0,984) | 3 | 90 | 50 | 40 | 3.0 | 17 | 4.5 | A 713041 |
| 33000 | 45 | (1,772) | 30 | (1,181) | 4 | 93 | 30 | 22 | 5.0 | 20 | 6.2 | A 713042 |
| 47000 | 45 | (1,772) | 40 | (1,575) | 6 | 115 | 30 | 20 | 7.0 | 20 | 7,6 | A 713044 |
| Rated voltage / Peak voltage: 35/40 V | | | | | | | | | | | | |
| 10000 | 45 | (1,772) | 21 | (0,827) | 2 | 56 | 68 | 52 | 2.1 | 14 | 3.7 | A 713060 |
| 15000 | 45 | (1,772) | 25 | (0,984) | 3 | 71 | 58 | 46 | 3.1 | 16 | 4.2 | A 713061 |
| 22000 | 45 | (1,772) | 30 | (1,181) | 4 | 86 | 48 | 33 | 4.6 | 19 | 4.9 | A 713064 |
| Rated voltage / Peak voltage: 50/58 V | | | | | | | | | | | | |
| 6800 | 45 | (1,772) | 21 | (0,827) | 2 | 39 | 70 | 53 | 2.0 | 14 | 3.6 | A 713080 |
| 10000 | 45 | (1,772) | 25 | (0,984) | 3 | 47 | 58 | 45 | 3.0 | 16 | 4.2 | A 713081 |
| 15000 | 45 | (1,772) | 35 | (1,378) | 5 | 59 | 48 | 33 | 4.5 | 20 | 5.2 | A 713083 |
| 22000 | 45 | (1,772) | 40 | (1,575) | 6 | 72 | 35 | 25 | 6.6 | 20 | 6.4 | A 713084 |
| Rated voltage / Peak voltage: 63/72 V | | | | | | | | | | | | |
| 4700 | 45 | (1,772) | 21 | (0,827) | 2 | 28 | 75 | 55 | 1.8 | 13 | 3.5 | A 713100 |
| 6800 | 45 | (1,772) | 30 | (1,181) | 4 | 33 | 60 | 45 | 2.6 | 17 | 4.4 | A 713102 |
| 10000 | 45 | (1,772) | 35 | (1,378) | 5 | 41 | 50 | 35 | 3.0 | 19 | 5.1 | A 713103 |
| 15000 | 45 | (1,772) | 40 | (1,575) | 6 | 54 | 33 | 28 | 5.7 | 20 | 6.6 | A 713104 |
| Rated voltage / Peak voltage: 80/92 V | | | | | | | | | | | | |
| 3300 | 45 | (1,772) | 21 | (0,827) | 2 | 20 | 75 | 55 | 1.6 | 13 | 3.5 | A 713120 |
| 4700 | 45 | (1,772) | 30 | (1,181) | 4 | 20 | 60 | 45 | 2.2 | 17 | 4.4 | A 713122 |
| 6800 | 45 | (1,772) | 35 | (1,378) | 5 | 23 | 40 | 30 | 3.2 | 20 | 5.7 | A 713123 |
| 10000 | 45 | (1,772) | 40 | (1,575) | 6 | 30 | 32 | 25 | 4.8 | 20 | 6.7 | A 713124 |
| Rated voltage / Peak voltage: 100/115 V | | | | | | | | | | | | |
| 2200 | 45 | (1,772) | 21 | (0,827) | 2 | 16 | 90 | 70 | 1.3 | 12 | 3.2 | A 713140 |
| 3300 | 45 | (1,772) | 30 | (1,181) | 4 | 20 | 75 | 60 | 2.0 | 15 | 3.9 | A 713142 |
| 4700 | 45 | (1,772) | 35 | (1,378) | 5 | 21 | 55 | 45 | 2.8 | 18 | 4.9 | A 713143 |
| Rated voltage / Peak voltage: 160/185 V | | | | | | | | | | | | |
| 680 | 45 | (1,772) | 21 | (0,827) | 2 | 13 | 230 | 190 | 0.65 | 7.5 | 2.0 | A 713160 |
| 1000 | 45 | (1,772) | 21 | (0,827) | 2 | 17 | 210 | 180 | 1.0 | 7.8 | 2.1 | A 713164 |
| 1500 | 45 | (1,772) | 25 | (0,984) | 3 | 24 | 200 | 170 | 1.4 | 8.5 | 2.3 | A 713165 |
| 2200 | 45 | (1,772) | 30 | (1,181) | 4 | 24 | 130 | 100 | 2.1 | 11 | 3.0 | A 713166 |
| Rated voltage / Peak voltage: 200/230 V | | | | | | | | | | | | |
| 680 | 45 | (1,772) | 21 | (0,827) | 2 | 11 | 170 | 130 | 0,81 | 8,7 | 2,3 | A 713200 |
| 1000 | 45 | (1,772) | 21 | (0,827) | 2 | 15 | 160 | 120 | 1,2 | 9 | 2,4 | A 713203 |
| 1500 | 45 | (1,772) | 30 | (1,181) | 4 | 20 | 140 | 110 | 1,8 | 11 | 2,9 | A 713204 |
| 2200 | 45 | (1,772) | 35 | (1,378) | 5 | 22 | 120 | 100 | 2,6 | 13 | 3,5 | A 713205 |
| Rated voltage / Peak voltage: 250/290 V | | | | | | | | | | | | |
| 470 | 45 | (1,772) | 21 | (0,827) | 2 | 11 | 250 | 200 | 0.70 | 7,2 | 1,9 | A 713200 |
| 680 | 45 | (1,772) | 21 | (0,827) | 2 | 11 | 170 | 130 | 1.0 | 8,7 | 2,3 | A 713203 |
| 1000 | 45 | (1,772) | 25 | (0,984) | 3 | 15 | 160 | 120 | 1.5 | 9,5 | 2,5 | A 713204 |
| 1500 | 45 | (1,772) | 35 | (1,378) | 5 | 20 | 140 | 110 | 2.3 | 11 | 3,1 | A 713205 |
| 2200 | 45 | (1,772) | 40 | (1,575) | 6 | 22 | 120 | 100 | 3.3 | 13 | 3.5 | A 713206 |
| Rated voltage / Peak voltage: 350/385 V | | | | | | | | | | | | |
| 330 | 45 | (1,772) | 21 | (0,827) | 2 | 10 | 290 | 190 | 0.69 | 6,7 | 1,8 | A 713220 |
| 470 | 45 | (1,772) | 25 | (0,984) | 3 | 10 | 220 | 160 | 1.0 | 8,1 | 2,2 | A 713221 |
| 680 | 45 | (1,772) | 30 | (1,181) | 4 | 10 | 150 | 120 | 1.4 | 10 | 2,8 | A 713225 |
| 1000 | 45 | (1,772) | 35 | (1,378) | 5 | 12 | 120 | 100 | 2.1 | 12 | 3,3 | A 713226 |
| Rated voltage / Peak voltage: 400/450 V | | | | | | | | | | | | |
| 220 | 45 | (1,772) | 21 | (0,827) | 2 | 10 | 470 | 360 | 1.2 | 5.2 | 1.4 | A 713240 |
| 330 | 45 | (1,772) | 25 | (0,984) | 3 | 12 | 400 | 280 | 1.5 | 6.0 | 1.6 | A 713241 |
| 470 | 45 | (1,772) | 30 | (1,181) | 4 | 13 | 300 | 250 | 1.8 | 7.4 | 2.0 | A 713242 |
| 680 | 45 | (1,772) | 35 | (1,378) | 5 | 13 | 240 | 200 | 2.1 | 8.8 | 2.3 | A 713243 |
| 820 | 45 | (1,772) | 40 | (1,575) | 6 | 13 | 160 | 120 | 2.3 | 11 | 3.0 | A 713244 |

SNAPSIC 105 LP

8 000 h / 105°C

| Capacitance (μF) | Dimensions | | Can size | Tan δ 100 Hz +20°C max. (%) | ESR 100 Hz +20°C Typic ($\text{m}\Omega$) | Z 10 kHz +20°C Typic ($\text{m}\Omega$) | II +20°C 5 min. max. (mA) | I \sim 100 Hz | | Code | | |
|--|------------------------------|------------------|----------|--|--|--|---------------------------------------|----------------------|-----------------------|------|-----|----------|
| | \varnothing mm (inches) | H mm (inches) | | | | | | +40°C max. (A) | +105°C max. (A) | | | |
| Rated voltage / Peak voltage: 450/500 V | | | | | | | | | | | | |
| 150 | 45 | (1,772) | 21 | (0,827) | 2 | 10 | 600 | 400 | 1.00 | 4,6 | 1,2 | A 713260 |
| 220 | 45 | (1,772) | 21 | (0,827) | 2 | 13 | 500 | 350 | 1.25 | 5,1 | 1,4 | A 713266 |
| 330 | 45 | (1,772) | 30 | (1,181) | 4 | 13 | 300 | 230 | 1.50 | 7,4 | 2,0 | A 713262 |
| 440 | 45 | (1,772) | 30 | (1,181) | 4 | 13 | 280 | 220 | 1.70 | 7,7 | 2,0 | A 713265 |
| 470 | 45 | (1,772) | 35 | (1,378) | 5 | 13 | 270 | 210 | 1.80 | 8,3 | 2,2 | A 713263 |
| 560 | 45 | (1,772) | 35 | (1,378) | 5 | 13 | 250 | 170 | 2.0 | 8,6 | 2,3 | A 713267 |
| 680 | 45 | (1,772) | 40 | (1,575) | 6 | 13 | 220 | 140 | 2.2 | 9,6 | 2,6 | A 713268 |
| Rated voltage / Peak voltage: 500/550 V | | | | | | | | | | | | |
| 150 | 45 | (1,772) | 21 | (0,827) | 2 | 15 | 1200 | 900 | 1.1 | 3.3 | 0.9 | A 713283 |
| 220 | 45 | (1,772) | 25 | (0,984) | 3 | 15 | 850 | 690 | 1.4 | 4.1 | 1.1 | A 713285 |
| 330 | 45 | (1,772) | 35 | (1,378) | 5 | 15 | 500 | 350 | 1.6 | 6.1 | 1.6 | A 713286 |
| 470 | 45 | (1,772) | 40 | (1,575) | 6 | 17 | 430 | 310 | 1.9 | 6,9 | 1,8 | A 713287 |

CASE BOTTOM CONDUCTION COOLING

with radiator or frame put on the case bottom ripple current I_0 is multiplied by 2 to 3. For more details, contact us.

PERMISSIBLE RIPPLE CURRENT I (R.M.S. VALUE)

versus frequency f :

I \sim : permissible r.m.s. current at 100 Hz

| f [Hz] | 50 | 100 | 300 | 600 | 1 000 | 10 000 | $\geq 50 000$ |
|--------|----------------|----------|----------------|----------------|-----------------|----------------|----------------|
| I | 0,8 x I \sim | I \sim | 1,2 x I \sim | 1,3 x I \sim | 1,35 x I \sim | 1,5 x I \sim | 1,6 x I \sim |

EXPECTED LIFE

as a function of temperature and ripple current

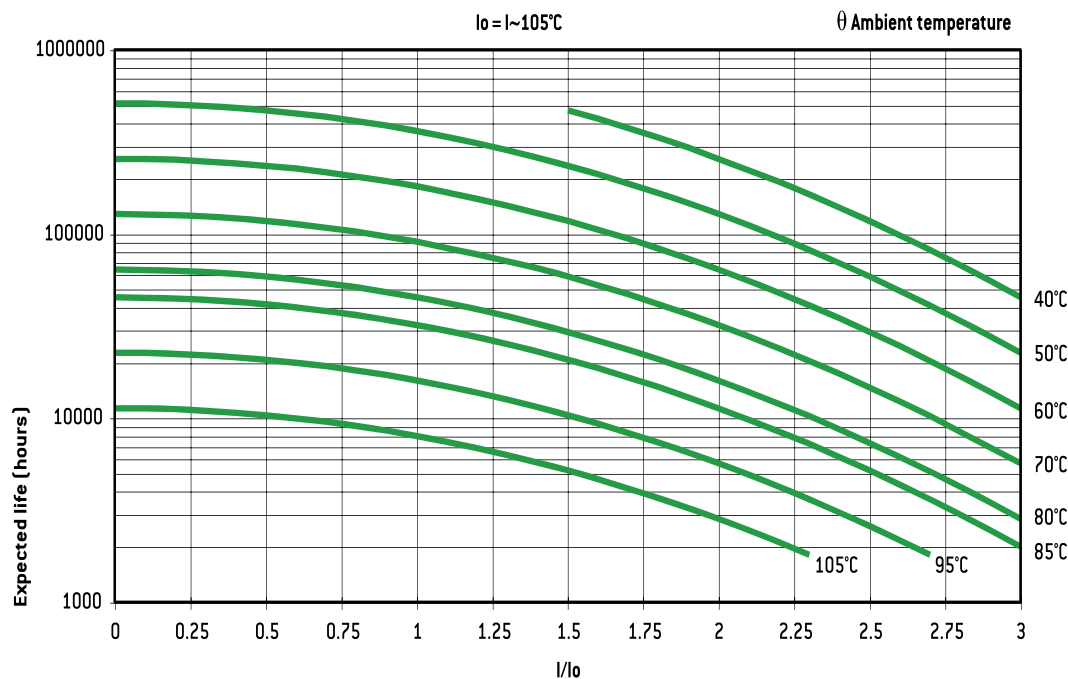

General technical data

1. BASIC CONSTRUCTION

Structure of an electrolytic aluminum capacitor is shown hereunder:

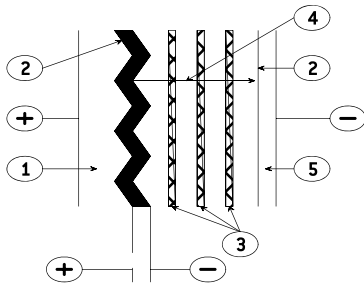

1. Anode: aluminum foil
2. Dielectric: aluminum oxide
3. Papers spacers impregnated with electrolyte
4. Ionic conduction assumed by electrolyte
5. Cathode: aluminum foil

The positive plate is an etched aluminum foil covered with alumina which is the dielectric of the capacitor.

The negative plate is constituted by a second aluminum foil which serves as a current supply, and by electrolyte-impregnated papers layers.

The metal used for anode is a $\geq 99,98$ % grade aluminum.

The dielectric has a thickness of $13 \text{ \AA} / \text{V}$.

The aluminum used for the cathode is a ≥ 98 % grade aluminum covered with a dielectric layer with a thickness of about 40 \AA .

2. DIAGRAM OF THE EQUIVALENT CIRCUIT

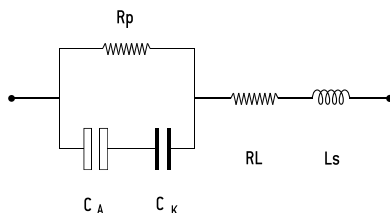

- C_A = Capacitance of the anode
- C_K = Capacitance of the cathode
- R_p = Parallel resistance due to the aluminum oxide film.
- R_L = Series resistance of connections, plates and impregnated spacer.
- L_s = Inductance of winding and connections.

A standard simplified diagram is.

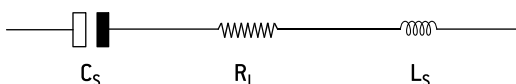

C_s is the series capacitance of both anode and cathode capacitances. Electrolytic aluminum capacitors are naturally polarized because of the insulating film on the anode. Given the very thin aluminum oxide layer, a reversed voltage should not exceed 1.5 V when there is energy supply.

Short duration reverse voltages can be absorbed by special construction, second anode replacing the former cathode.

3. CAPACITORS MARKING

3.1. ARTICLE CODE (ON EACH PACKAGING)

A followed by 6 figures number. First 3 positions are specific of the range. (Ex. A 745xxx for a FELSIC 85 BD)

| | |
|--------------------------------|--------------------------------|
| 140 FELSIC in bank | 741 FELSIC 125 FRS BD (ex 731) |
| 701 PRORELSIC 125 | 742 PRORELSIC 105 TFRS |
| 703 PRORELSIC 125 | 743 PRORELSIC 105 TFRS |
| 704 SNAPSIC | 744 FELSIC 85 BC |
| 705 SNAPSIC 105 | FELSIC 85 LP |
| 706 FELSIC HP BC – BD | 745 FELSIC 85 BD |
| 708 PRORELSIC 145 | 746 FELSIC 85 M BC |
| 710 CUBISIC | 747 FELSIC 85 M BD |
| 711 PROMISIC 031 | 748 SICAL CO 42 - SICAL |
| 712 CUBISIC LP | 749 SICAL CO 42 - SICAL |
| 713 SNAPSIC 105 LP | 750 CUBISIC 125 |
| 714 SNAPSIC 4P | 756 FELSIC 105 BC |
| 715 SNAPSIC 105 4P | FELSIC 105 LP |
| 716 SNAPSIC HV | 757 FELSIC 105 BD |
| 717 SNAPSIC HC | 760 FELSIC HC BC |
| 718 SNAPSIC 125 | 761 FELSIC HC BD |
| 721 RELSIC 033 | 762 FELSIC 105 TFRS BC |
| 722 CI FRS | 763 FELSIC 105 TFRS BD |
| 723 CI FRS | 764 FELSIC HV BC |
| 728 FELSIC 039 (ex 727) | 765 FELSIC HV BD |
| FELSIC DI | 775 VACSIC |
| 738 FELSIC 037 (ex 737) | 774 VACSIC 150 |
| 740 FELSIC 125 FRS BC (ex 731) | 776 ALSIC 20G |
| | ALSIC 145 20G |

In FELSIC ranges, article code without first letter A, is printed on each capacitor.

a Figure 9 in fourth position shows a special product.

3.2. BATCH (ON EACH CAPACITOR).

3 figures or 6 figures

3.3. DATE (ON EACH CAPACITOR IF APPLICABLE)

4 figures (year-week)

4. ELECTRICAL CHARACTERISTICS

4.1. RATED CAPACITANCE C_R

The rated capacitance is defined at 100 Hz and at ambient temperature.

4.2. RATED VOLTAGE U_R

U_R is the maximum DC voltage which may be applied in continuous operation.

When applying a superimposed alternating voltage, the peak value of the resulting waveform should not exceed the rated voltage.

4.3. PEAK VOLTAGE U_p

U_p is the maximum repetitive voltage which can be applied within short periods.

Defined in CECC 30 300 and IEC 60 384-4:

1000 cycles of 30 s charge followed by a no load period of 5 min. 30 s with upper category temperature.

$$U_p \leq 1,15 U_R (U_R \leq 315 \text{ V})$$

$$U_p \leq 1,10 U_R (U_R > 315 \text{ V})$$

General technical data

4.4. DISSIPATION FACTOR $\tan\delta$

The dissipation or loss factor is defined by its tangent $\tan\delta$

$$\tan\delta = R_s C_s \omega$$

$$(\omega = 2\pi F)$$

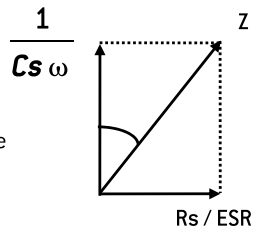

- ESR** Capacitor Equivalent Series Resistance
Cs Capacitor capacitance
F Frequency (100 Hz)
Z Capacitor impedance

4.5. EQUIVALENT SERIES RESISTANCE ESR

The relation between ESR and dissipation factor $\tan\delta$ is given in § 4.4.

4.6. IMPEDANCE Z - INDUCTANCE L

The impedance is given by:

$$Z = \sqrt{R^2 + \left[L\omega - \frac{1}{C\omega}\right]^2}$$

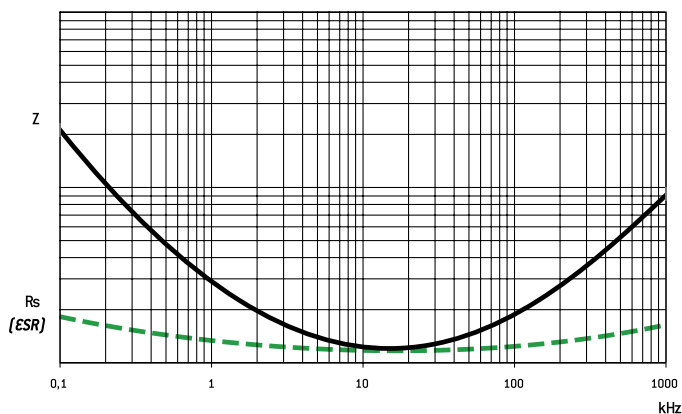

L inductance. Generally L = 5 to 20 nH
 Z and ESR as function of frequency typically follows the chart:

4.7. PERMISSIBLE RIPPLE CURRENT (I r.m.s.) I~

The current is defined at the maximum climatic category and at 100 Hz. It is the root mean square value r.m.s. The value I_0 is the rated value for calculations of expected life up to 3 I_0 .

4.8. LEAKAGE CURRENT II

I_l is measured at 20°C after a 5 min. polarization under rated voltage.

For C_R in μF and U_R in V:

$$I_l \leq 0,01 C_R U_R \text{ or } 1 \mu A^*$$

when $C_R U_R \leq 1000 \mu C$

$$I_l \leq 0,006 C_R U_R + 4 \mu A$$

when $C_R U_R > 1000 \mu C$

For $U_R > 350 V_{DC}$ it can be specified:

with $K = 4, 6$ or 8

or

$$I_l \leq 0,3 [C_R U_R]^{0,7} + 4 \mu A \text{ (CECC 30 300)}$$

* Whichever is the greater

4.9. CHARACTERISTICS

Versus temperature (typical values).

4.9.1. Capacitance drift

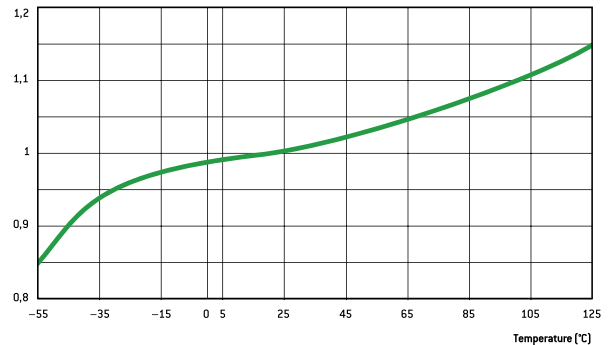

Versus temperature

4.9.2. ESR and Z drifts at 100 Hz

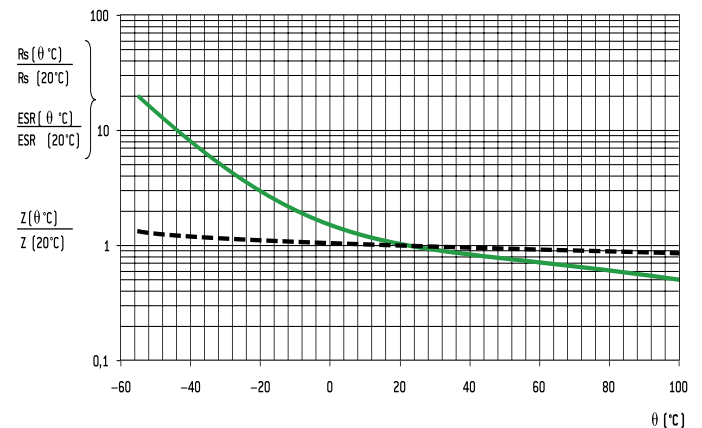

Versus temperature

4.9.3 Leakage current drift

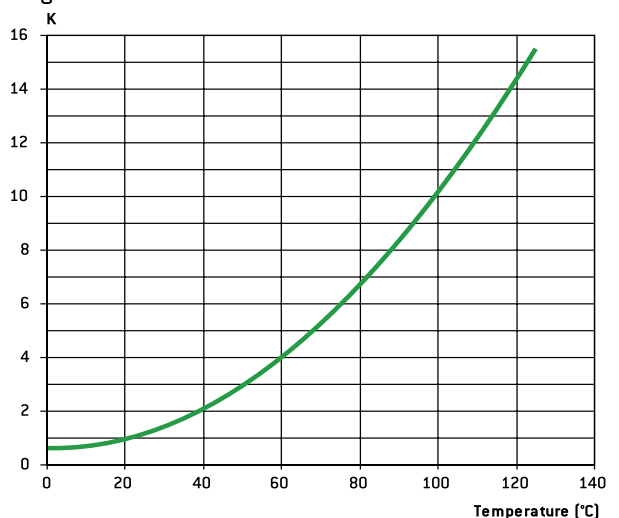

Versus temperature

General technical data

5. SPECIFICATION TO APPLY

Electrolytic aluminum capacitors are defined in:

- NF and UTE French national standard
- CECC European specifications
- IEC international specifications

Quality insurance procedures are described in these specifications.

| | French | European | International |
|--|---|--|---------------------------------|
| Generic specification Fixed capacitors | NF C 83 100 | CECC 30 000 EN 130 000 | IEC 60 384 -1 QC 300 000 |
| Sectional specification Electrolytic aluminum capacitors | NF C 83 110 | CECC 30 300 | IEC 60 384 - 4 C 300 300 |
| Blank deta II specification - Electrolytic aluminum capacitors with non solid electrolyte. | UTE 83 110 | CECC 30 301 | IEC 60 384 - 4 -1 QC 300 301 |
| Blank deta II specifications | CECC 30 301- 017 to CECC 30 301- 062 C0 31 to C0 55 | CECC 30 301- 017 to CECC 30 301- 062 CECC 30 301- 802 to CECC 30 301- 811 | |

6. ENDURANCE TESTS / LIFE TIME

6.1. STANDARD ENDURANCE TEST

at max category temperature:

Standard endurance tests do not exceed 2000 hours at 125°C. However,

| Temperature | Endurance test | | | |
|-------------|---------------------|---------|---------|----------------------------|
| | Grade I - Long life | | | Grade II - General purpose |
| | 10 000 h | 5 000 h | 2 000 h | 1 000 h |
| 125°C | | | • | |
| 105°C | | • | • | • |
| 85°C | • | • | • | • |

present EXXELIA technologies concerning liquid electrolytes have led to endurance tests up to 5000 hours at 125°C (PRORELSIC 125 - FELSIC 125 RS) and even 20000 hours at 125°C (PRORELSIC 145 - ALSIC 145)

6.2. PERFORMANCE REQUIREMENTS ON STANDARD ENDURANCE TESTS.

Permissible capacitance drift $\Delta C/C$ (%)

Permissible increase factors on $\tan\delta$, ESR, Z and II initial values

(1) $\tan\delta$ or ESR: for initial value, take standard value.

| U_R | Endurance test | | | |
|--------------|----------------|---------|---------|----------|
| | Grade I | | | Grade II |
| | 10 000 h | 5 000 h | 2 000 h | 1 000 h |
| 6,3 V | | | +15 -30 | +25 -40 |
| 10 V - 35 V | +15 -20 | ±15 | ±15 | ±30 |
| 40 V - 160 V | ±15 | ±15 | ±15 | ±30 |
| > 160 V | ±15 | ±10 | ±10 | ±15 |

| | Endurance test | | | |
|-------------------------|-----------------|---------|---------|----------|
| | Grade I | | | Grade II |
| | 10 000 h | 5 000 h | 2 000 h | 1 000 h |
| $\tan\delta$ or ESR [1] | 1,5 | 1,3 | 1,3 | 1,5 |
| Z [2] | 3 | 2 | 2 | 3 |
| II | Standard values | | | |

[2] Z: for initial value, take specified value [see data sheet].

Specific requirements can be taken into consideration with regards to initial values of dissipation factor or equivalent series resistance and impedance.

6.3. FAILURE CRITERIA FOR ELECTROLYTIC CAPACITORS.

Failure criteria are defined in CECC 30 301

- Non measurable defaults leading to complete failure.
- Measurable defaults leading to adjustment losses of the load circuit (failure due to variations).

6.3.1. Non measurable defaults.

They might be summed up as:

- Open circuit
- Short circuit
- Operation of pressure relief device
- Severely damaged insulation
- Unusable terminations

6.3.2. Measurable defaults.

Variations exceeding the values given below characterize a default.

- Capacitance drift $\Delta C/C$ (%): 3 times the limit for standard endurance testing or 50 % (whichever is the smallest).
- $\tan\delta$ or ESR: 3 times standard max initial values.
- Z: 3 times standard max initial values.
- II: initial limit (under load conditions).

Specific requirements can be taken into consideration with regards to lower drifts.

6.4. INFLUENCE OF MAIN PARAMETER ON OPERATIONAL LIFE.

6.4.1. Temperature.

The capacitors operational life is highly dependent upon its internal temperature Θ_i and therefore upon the ambient temperature and the ripple current.

Knowing ESR and dissipated power values (§ 6.4.3.) one can figure out, the internal temperature rise and then determine the capacitors expected life.

With present high boiling point electrolytes (§ 8.6)

Θ_i max = 125 to 185°C depending on styles.

6.4.2. Ripple current.

The ripple current flowing through the capacitor increase the internal temperature through power dissipation.

Standards define the permissible current at 100 Hz and generally consider a temperature rise of 5 to 10°C of max category temperature.

Current waveforms and frequencies make it difficult to clearly determine the capacitors internal temperature rise, which defines the operationally life.

Experiments confirm following relationship:

$$\Theta_i = \Theta_a + (\Theta_c - \Theta_a) K$$

Where:

- Θ_i = Internal hot spot temperature
- Θ_a = Ambient temperature
- Θ_c = Case temperature
- K = Parameter depending upon case diameter and cooling
 - $\emptyset \geq 51$ k = $2 \pm 0,5$
 - $\emptyset < 51$ k = $1,5 \pm 0,5$ [air cooling - 0,2 m/s]

General technical data

r.m.s. value according to current waveform.

one capacitor diameter

| Function | Mean value | R.m.s. value | Function | Mean value | R.m.s. value | Function | Mean value | R.m.s. value |
|----------|---------------|--------------------|----------|------------------|-------------------|----------|------------|--------------|
| | $A (t_0/T)$ | $A \sqrt{t_0/T}$ | | $A/2$ | $A \sqrt{3}$ | | $2A/\pi$ | $A/\sqrt{2}$ |
| | $A (t_1/T)$ | $A \sqrt{2t_1/3T}$ | | $2A/\pi (t_0/T)$ | $A \sqrt{t_0/2T}$ | | $A/2$ | $A/\sqrt{3}$ |
| | $A/2 (t_0/T)$ | $A \sqrt{t_0/3T}$ | | $A/2 (t_0/T)$ | $A \sqrt{t_0/3T}$ | | 0 | A |

6.4.3. Dissipated power versus case dimension

For calculations of ripple currents, considering an internal

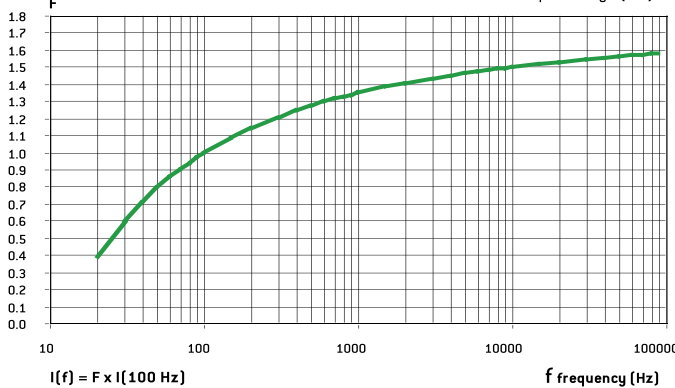
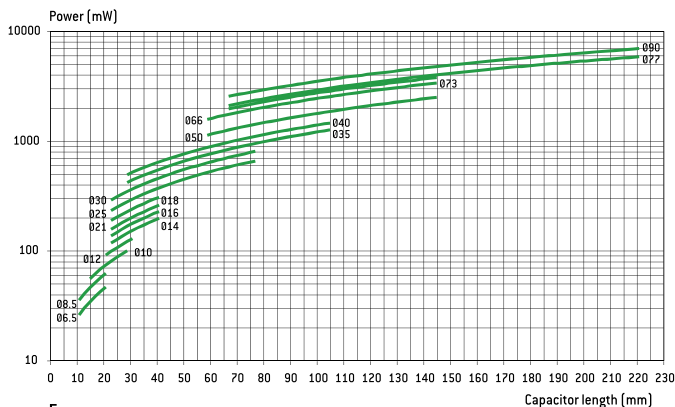

temperature rise of 10°C

$$P = ESR \cdot I^2$$

P = Dissipated power (mW)

($\Theta_i - \Theta_a = 10^\circ\text{C}$)

ESR: Equivalent series resistance (100 Hz 20°C)

I: Ripple current (r.m.s. value at 100 Hz)

For different frequencies from 100 Hz, I must be multiplied by the factor F, according to above chart.

6.4.4. Thermal resistance Rth and air cooling

Rth is static thermal resistance (without cooling) between capacitor central hot spot and ambient temperature measured at a distance of

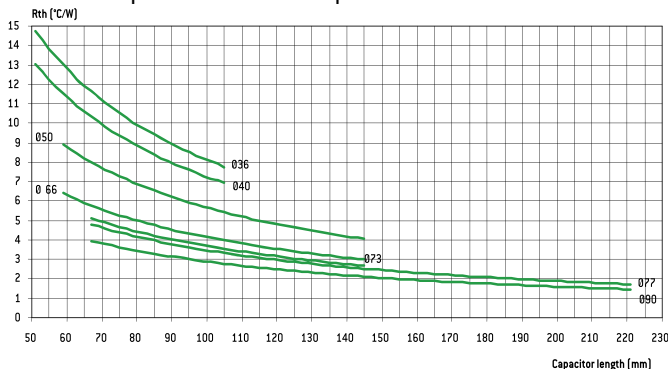

Forced or not cooling air can lead to a significant decrease of these values.

Consequently, r.m.s. ripple current can be increased as a function of air cooling speed:

| Ø mm (inches) | ≤ 0,5 m/s | 1 m/s | 2 m/s | 3 m/s | ≥ 4 m/s |
|---------------|-----------|-------|-------|-------|---------|
| 66 - 90 | 1~ | 1,1~ | 1,2~ | 1,25~ | 1,3~ |
| 36 - 51 | 1~ | 1,2~ | 1,4~ | 1,45~ | 1,5~ |

This parameter shall be applied to one capacitor alone.

For capacitors in bank, ambient temperature must be strictly equal around all capacitors.

6.4.5. Quality guaranty

We guarantee products manufactured during 2 years from the data of shipment against defaults of material and assembly.

This guaranty can be involved by the buyer only if our products are used within normal conditions, always according to the state of the art and taking in account storage conditions.

The equipment design should take into consideration possible failures of our capacitors and related effects in order to avoid them.

Guaranty is not applicable for damages occurred by surge voltage, irregular use, polarity inversion or maintenance default.

Guaranty is exclusively limited to the replacement of individual defective capacitors within the terms of delivery. This rule applied to all cases and particularly to any further consequence of failures.

6.4.6. Reliability

Failure rate: _____

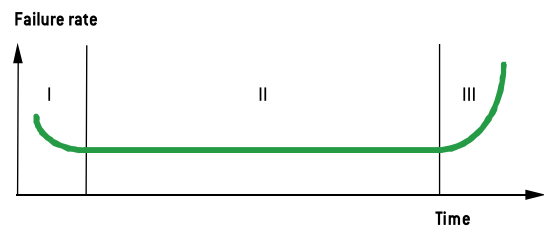

$$FR = \frac{\text{Number of components tested} \times \text{test duration}}{\text{Number of failures}}$$

Failure rate is measured in FIT (failure in time = 10^{-9} / hour).

The failure rate is set up during the life time of the capacitor (phase II)

I. Early failure phase (generally excluded during ageing process).

II. Operational life time of the capacitors

III. End of life

General technical data

Mean time between failures MTBF = 1/FR mesured in years

| Range | Failure rate for a failure percentage not exceeding 1% with a confidence level of 60 % |
|--|--|
| FELSIC 85 >350 V FELSIC HC > 350 V SNAPSIC - SNAPSIC HC > 350 V SNAPSIC 4P > 350 V PROMISIC 031 Ø = 6,5 SICAL CO 42 - SICAL > 350 V | 50 FIT - (MTBF = 2280) |
| FELSIC 037 - 039 FELSIC 85 ≤ 350 V FELSIC HC ≤ 350 V CUBISIC CI FRS SNAPSIC 105 - SNAPSIC 105 4P SNAPSIC 105 LP - SNAPSIC HV SNAPSIC - SNAPSIC 4P ≤ 350 V SNAPSIC HC ≤ 350 V ALSIC IR - ALSIC 145 - ALSIC HV - VACSIC 150 - VACSIC SICAL CO 42 - SICAL ≤ 350 V PRORELSIC 125 Ø = 6,5 RELSIC 033 PROMISIC 031 Ø > 6,5 | 25 FIT - (MTBF = 4560) |
| FELSIC 125 FRS - SNAPSIC 125 FELSIC HV - FELSIC 105 | 10 FIT - (MTBF = 11410) |
| PRORELSIC 125 Ø > 6,5 PRORELSIC 145 | 5 FIT - (MTBF = 22820) |

Multiplying factor of FR with voltage and temperature

| | Temperature (°C) | | | | | | | |
|--------|------------------|-----|-----|-----|-----|---------|---------|---------|
| | ≤ 40 | 50 | 60 | 70 | 85 | 105 (1) | 125 (1) | 145 (1) |
| Factor | 1 | 1,5 | 2,3 | 3,4 | 6,3 | 14 | 32 | 72 |

(1) Only for permitted capacitors

| | Percentage of rated voltage (2) | | |
|--------|---------------------------------|------|------|
| | 100 % | 80 % | 50 % |
| Factor | 1 | 0,8 | 0,5 |

(2) This voltage has to be constant

| Environ- ment | Without vibration | | Ground with vibrations or mob ile | | | |
|------------------|----------------------------------|-------------|--|--|--|-------|
| | Ground, fix Controlled air | Ground, fix | PRORELSIC SNAPSIC 20 g FELSIC 20 g | FELSIC 10 g PROMISIC SICAL Ø ≤14 | CI FRS - SNAPSIC RELSIC SICAL Ø >14 | ALSIC |
| Factor | 1 | 2 | 2 | 4 | 6 | 12 |

7. MANUFACTURING FLOW CHART

Process controls

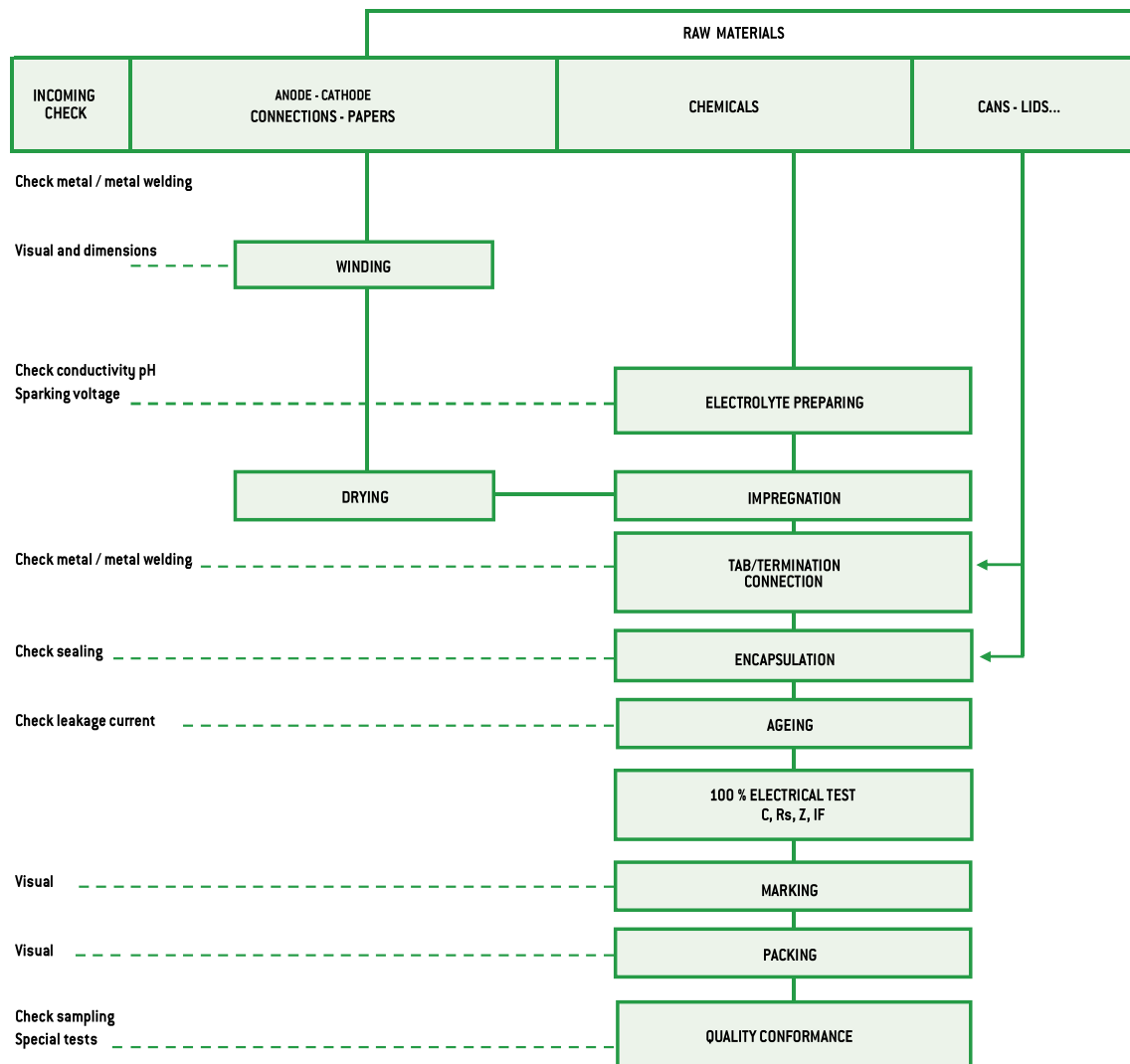

General technical data

8. INFORMATION ON APPLICATION

8.1. CLEANING SOLVENTS

Use aliphatic alcohols, such as denatured ethyl alcohol, isopropanol, or butylacetate, or else alkaline diluted solutions. Avoid incompatible solvents (halogenous for example).

8.2. SHELF LIFE

There is no electrical characteristics variation for long periods of storage except leakage current which can increase.

It is caused by chemical reactions between the dielectric alumina and the electrolyte. These reactions are reversible when switched on. Capacitors can generally be stored at temperature between -5° and $+50^{\circ}\text{C}$ without reforming for the following periods of time:

- For $U_R \leq 100\text{ V}$, storage time: 5 years (up to 10 years under specific conditions)
- For $100\text{ V} < U_R \leq 360\text{ V}$ storage time: 3 years
- For $360\text{ V} < U_R < 500\text{ V}$ storage time: 1 year
- For $U_R \leq 500\text{ V}$, storage time: 6 months

Generally when these periods are overstepped, one hour at rated voltage causes the decrease of leakage current under the specified limits. An other way to avoid this leakage current increase problem is to always limit available power through capacitor during first seconds or minutes after storage or transport, according to the following chart:

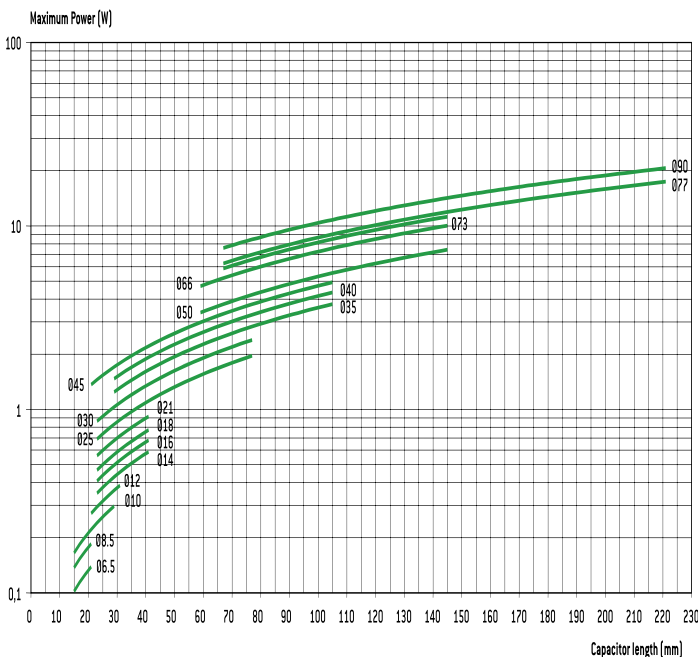

8.3. LOW PRESSURE RESISTANCE

EXXELIA capacitors can be used with ambient low pressure decreasing up to 10 mbar (altitude 28000 m – 92000 feet).

8.4. MOUNTING SCREW TERMINALS CAPACITORS (FELSIC)

Capacitors may be used vertically (terminals on top) or horizontally. When used horizontally, the following position in relation to the safety vent, is recommended:

Mounting capacitors in series may be used for operating voltage exceeding U_R . See FELSIC in bank.

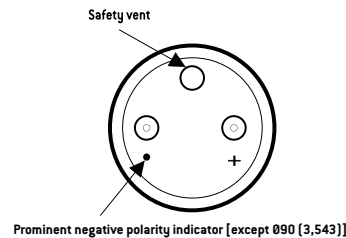

8.5. MOUNTING SOLDER TYPE CAPACITORS.

They may be used in any position. During mounting, avoid applying excessive force to capacitor pins or wires. There is a risk of damaging internal connections.

After soldering and for the same reasons, do not try to move the capacitor's body.

8.6. ELECTROLYTES: SAFETY RULES.

Electrolytes used in EXXELIA capacitors are manufactured by EXXELIA. Main solvents are generally γ butyrolactone and ethylene glycol, very stable high boiling point solvents. Ionic conductive salts in electrolyte induce a very weak acidity (pH 5 to 7).

8.7. ENVIRONMENT.

In aluminium capacitors with liquid electrolyte there is no component showing a pollution risk, in small amounts, of air or water. EXXELIA is always involved in this security field particularly in using chemicals for electrolyte, without well-known risks.

- Dimethylformamide (DMF) dangerous solvent forbidden in several uses is completely excluded by EXXELIA, since 1990.
- There is no halogen compound such as chlorofluorocarbon (CFC or FCKW in German) or polychlorobiphenyl (PCBPyrallene) or pentabromodiphenylether or octabromodiphenylether.

There is neither benzene, toluene or phenyl compound nor explosive such as picric acid, nor asbestos in plastic covers. All the capacitors made by EXXELIA since 1991, can be scrapped or used in raw materials recycling processes without special care in compliance with Community rules.

EXXELIA aluminium capacitors with non-solid electrolyte are particularly suitable for different kinds of environment taking in account severity increasing laws.

European directives 2003/11/EC, 2002/96/EC (WEEE) and 2002/95/EC (RoHS) applies to all EXXELIA capacitors including every solder type, manufactured with pure tin coated pins or wires, since at least January 2006.

Mounting and insulating parts

STUD FIXING: FELSIC BD

Steel nut, spring washer and insulating washer are delivered loosely with the capacitor.

STANDARD MOUNTING WITH:

Insulating washer and steel nut

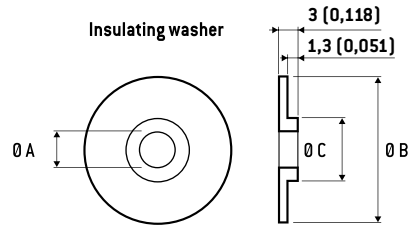
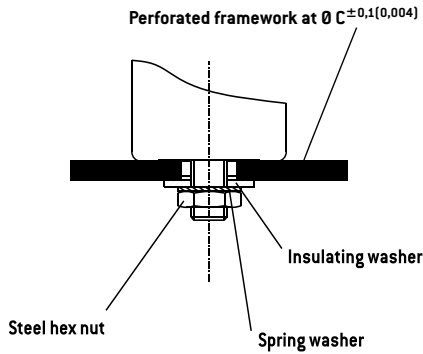

| Ø Capacitor | DIMENSIONS in mm (inches) | | | | |
|-------------|---------------------------|------|-----|------|----------|
| | M | Ø A | Ø B | Ø C | Code |
| 36 | 8 | 8,4 | 25 | 18,5 | A 691060 |
| 51 - 77 | 12 | 12,5 | 30 | 21,5 | A 691061 |
| 90 | 12 | 12,5 | 35 | 21,5 | A 691062 |

Insulating plastic nut with or without insulating washer

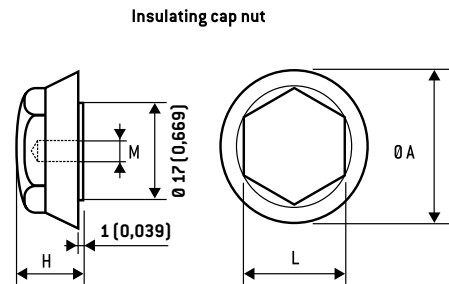
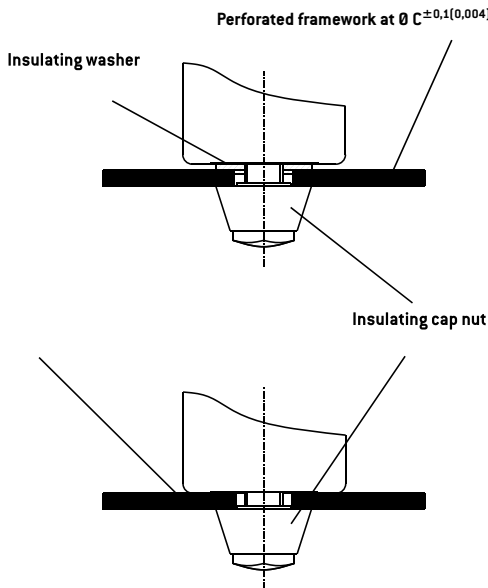

| DIMENSIONS in mm (inches) | | | | | |
|---------------------------|------------|------------|------------|-------------|----------|
| M | Ø A | H | L | Max. torque | Code |
| 8 (0,315) | 25 (0,984) | 15 (0,591) | 17 (0,669) | 3 Nm | A 691070 |
| 12 (0,472) | 30 (1,181) | 20 (0,787) | 19 (0,748) | 7 Nm | A 691071 |

Ring - clip mounting: FELSIC LP

Ring clips shall be ordered separately.

Tightening screws and nuts are supplied loosely.

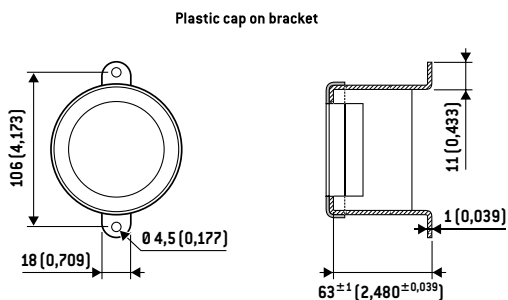

| FELSIC 85 LP FELSIC 105 LP | Code |
|-------------------------------|---------|
| Metal bracket | A691055 |
| Plastic cap | A691065 |

General technical data

Ring - clip mounting: FELSIC BC

Ring clips shall be ordered separately.

Tightening screws and nuts are supplied loosely.

FELSIC BC - Metal ring-clips

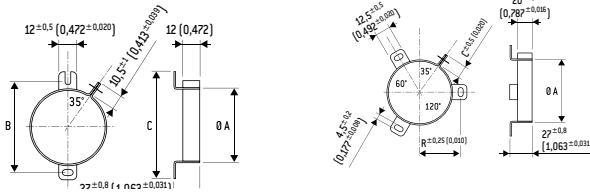

| Ø A Cap. | B | C | Code | Ø A Cap. | B | C | Code |
|----------|----|----|----------|----------|------|------|----------|
| 36 | 54 | 63 | A 691901 | 51 | 33,5 | 11,8 | A 691905 |
| | | | | 66 | 39 | 10,5 | A 691913 |
| | | | | 73 | 44 | 10,5 | A 691914 |
| | | | | 77 | 44,5 | 10,5 | A 691907 |
| | | | | 90 | 53,3 | 11,8 | A 691915 |

Stirrup mounting: CUBISIC LP

Stirrups shall be ordered separately.

Tightening screws and nuts are supplied loosely

Salt mist endurance of screws and mounting accessories:
minimum 96 h (IEC 600 68-2-11)

CUBISIC /CUBISIC LP - Metal bracket

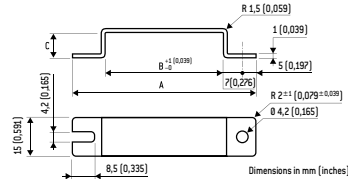

| Ø A Cap. | A | B | C | Code |
|---------------------|------------|------------|------------|----------|
| 45x12 (1,772x0,472) | 69 (2,717) | 45 (1,772) | 10 (0,394) | A 691057 |
| 35x16 (1,378x0,630) | 59 (2,323) | 35 (1,378) | 14 (0,551) | A 691059 |

PACKAGING

1. PACKAGING AND WEIGHT UNITS.

1.1. Capacitor with screw terminals

| Can DIMENSIONS in mm (inches) | | | | Unit weight * |
|-------------------------------|-------------|-------------|------------|---------------|
| Ø | H | | | (g) |
| 36 (1,417) | 47 (1,850) | 52 (2,047) | 53 (2,087) | 70 |
| 36 (1,417) | 60 (2,362) | | | 79 |
| 36 (1,417) | 80 (3,150) | 81 (3,189) | | 100 |
| 36 (1,417) | 104 (4,094) | 105 (4,134) | | 120 |
| 51 (2,008) | 47 (1,850) | | | 80 |
| 51 (2,008) | 62 (2,441) | 63 (2,480) | | 105 |
| 51 (2,008) | 81 (3,189) | 82 (3,228) | | 190 |
| 51 (2,008) | 104 (4,094) | 105 (4,134) | | 260 |
| 51 (2,008) | 112 (4,409) | | | 270 |
| 51 (2,008) | 144 (5,669) | | | 370 |
| 66 (2,598) | 104 (4,094) | 105 (4,134) | | 430 |
| 66 (2,598) | 112 (4,409) | | | 460 |
| 73 (2,874) | 104 (4,094) | 112 (4,409) | | 600 |
| 73 (2,874) | 144 (5,669) | | | 680 |
| 77 (3,031) | 104 (4,094) | 105 (4,134) | | 620 |
| 77 (3,031) | 144 (5,669) | 145 (5,709) | | 860 |
| 77 (3,031) | 200 (7,874) | | | 1300 |
| 77 (3,031) | 220 (7,874) | 221 (8,701) | | 1400 |
| 90 (3,543) | 67 (2,638) | | | 600 |
| 90 (3,543) | 144 (5,669) | 145 (5,709) | | 1400 |
| 90 (3,543) | 200 (7,874) | | | 1800 |

* Unit weight = typical values

Possible variations of = ± 25 % according to different voltage and capacitance.

1.2. Radial solder types

| Can dimensions mm (inches) | | | ALSIC | SNAP-SIC | Can dimensions | | AL-SIC | SNAP-SIC |
|----------------------------|------------|-------------|-------|----------|----------------|-------------|--------|----------|
| Ø | H | Weight* (g) | | | Ø | H | | |
| 10 (0,394) | 16 (0,630) | 1,8 | - | | 35 (1,378) | 30 (1,181) | - | 50 |
| 12,5 (0,492) | 21 (0,827) | 4,5 | - | | 35 (1,378) | 40 (1,575) | - | 50 |
| 12,5 (0,492) | 24 (0,945) | 5 | - | | 35 (1,378) | 45 (1,772) | - | 52 |
| | | | | | 35 (1,378) | 50 (1,969) | - | 60 |
| 16 (0,630) | 25 (0,984) | 8,2 | - | | 35 (1,378) | 75 (2,953) | - | 95 |
| | | | | | 35 (1,378) | 100 (3,937) | - | 125 |
| 22 (0,866) | 25 (0,984) | - | 15 | | 40 (1,575) | 40 (1,575) | - | 65 |
| 22 (0,866) | 30 (1,181) | - | 17 | | 40 (1,575) | 50 (1,969) | - | 100 |
| 22 (0,866) | 40 (1,575) | - | 18 | | 40 (1,575) | 75 (2,953) | - | 130 |
| | | | | | 40 (1,575) | 100 (3,937) | - | 170 |
| 25 (0,984) | 25 (0,984) | - | 17 | | 45 (1,772) | 21 (0,827) | - | 50 |
| 25 (0,984) | 30 (1,181) | - | 20 | | 45 (1,772) | 30 (1,181) | - | 60 |
| 25 (0,984) | 35 (1,378) | - | 22 | | 45 (1,772) | 35 (1,378) | - | 73 |
| 25 (0,984) | 40 (1,575) | - | 25 | | 45 (1,772) | 45 (1,772) | - | 85 |
| 25 (0,984) | 45 (1,772) | - | 28 | | 45 (1,772) | 45 (1,772) | - | 110 |
| 25 (0,984) | 50 (1,969) | - | 30 | | 45 (1,772) | 75 (2,953) | - | 180 |
| | | | | | 45 (1,772) | 100 (3,937) | - | 240 |
| 30 (1,181) | 25 (0,984) | - | 28 | | | | | |
| 30 (1,181) | 30 (1,181) | - | 30 | | | | | |
| 30 (1,181) | 35 (1,378) | - | 30 | | | | | |
| 30 (1,181) | 40 (1,575) | - | 40 | | | | | |
| 30 (1,181) | 45 (1,772) | - | 45 | | | | | |
| 30 (1,181) | 50 (1,969) | - | 50 | | | | | |

| Can DIMENSIONS in mm (inches) | | | CUBISIC |
|-------------------------------|------------|------------|------------|
| I | L | H | weight (g) |
| 35 (1,378) | 35 (1,378) | 16 (0,630) | 30 |
| 35 (1,378) | 50 (1,969) | 16 (0,630) | 40 |
| 45 (1,772) | 35 (1,378) | 12 (0,472) | 30 |
| 45 (1,772) | 50 (1,969) | 12 (0,472) | 45 |
| 45 (1,772) | 75 (2,953) | 12 (0,472) | 60 |

* Unit weight = typical values

Possible variations of = ± 25 % according to different voltage and capacitance.

1.3. Axial types

| Can DIMENSIONS in mm (inches) | | PRORELSIC RELSIC | PRORELSIC PROMISIC | SICAL CO 42 SICAL |
|-------------------------------|------------|-------------------|--------------------|-------------------|
| Ø | H | Unit weight * (g) | Unit weight * (g) | Unit weight * (g) |
| 6,5 (0,256) | 15 (0,591) | - | 1,6 | - |
| 6,5 (0,256) | 19 (0,748) | - | 1,8 | 1,8 |
| 8,5 (0,335) | 19 (0,748) | - | 2,3 | 2,3 |
| 10 (0,394) | 19 (0,748) | - | 2,8 | 2,8 |
| 10 (0,394) | 25 (0,984) | - | 3,5 | 3,5 |
| 10 (0,394) | 28 (1,102) | - | 3,8 | - |
| 12 (0,472) | 25 (0,984) | - | 5 | - |
| 12 (0,472) | 30 (1,181) | - | 5,4 | 5,4 |
| 14 (0,551) | 30 (1,181) | - | 6,9 | 6,9 |
| 14 (0,551) | 41 (1,614) | - | 9,5 | - |
| | 30 (1,181) | 7,7 | - | 7,7 |
| 18 (0,709) | 35 (1,378) | 13,6 | - | - |
| 18 (0,709) | 40 (1,575) | 15,3 | - | 15,3 |
| 21 (0,827) | 40 (1,575) | 19,5 | - | 19,5 |
| 25 (0,984) | 40 (1,575) | 28 | - | 28 |
| 25 (0,984) | 50 (1,969) | 35 | - | 35 |
| 25 (0,984) | 75 (2,953) | 56 | - | 56 |

* Unit weight = typical values

Possible variations of = ± 25 % according to different voltage and capacitance.

General technical data

2. PACKAGING ON TAPE

2.1. Axial types

Dimensions and tolerance in accordance with IEC 60 286-

(1) On tape only on request

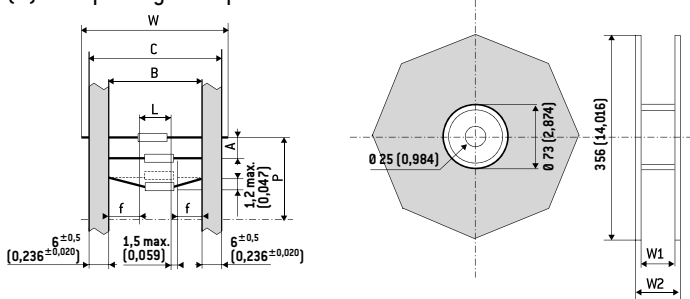

| DIMENSIONS in mm (inches) | | | | | | | | | |
|----------------------------|------------|----------------------------|----------------------------|-------------|--------------|----------------|---------------------|----------------------------|------------------|
| D | L max. | B | A | P | C max. | W ₁ | W ₂ max. | W | n ⁽²⁾ |
| 6,5 (0,256) | 20 (0,787) | 73 ^{±1,5} | 10 ^{±1,5} | ± 2 (0,079) | 87,5 (3,445) | 93 (3,661) | 106 (3,661) | 85 ^{±1,5} | 1000 (39,370) |
| 8,5 (0,335) ⁽¹⁾ | | (2,874 ^{±0,059}) | (0,394 ^{±0,059}) | | | | | (3,346 ^{±0,059}) | 750 (29,528) |
| 10 (0,394) ⁽¹⁾ | 32 (1,260) | 73 ^{±1,5} | 15 ^{±1,5} | ± 3 (0,118) | 87,5 (3,445) | 93 (3,661) | 106 (3,661) | 85 ^{±1,5} | 400 (15,748) |
| 12 (0,472) ⁽¹⁾ | | (2,874 ^{±0,059}) | (0,591 ^{±0,059}) | | | | | (3,346 ^{±0,059}) | 400 (15,748) |
| 14 (0,551) ⁽¹⁾ | | | | | | | | | 200 (7,874) |

(2) n = number of capacitors per reel.

White positive tape f: > 20 mm (0,787 inches)

P: 10 space