

SMD Power Inductors

SESI 18WR High Reliability Applications



- Energy storage, smoothing, filtering
- Applied standards: ECSS-Q-70-02, MIL-STD-202, D0-160
- ESCC 3201/009 versions upon request
- Materials meet UL94-V0 rating
- Suited for I_R and vapor reflow soldering
- Frequency range up to 1 MHz
- Operating temperature range: -55°C to +125°C
- Weight: 10 grams
- Shielded version upon request

Electrical Data (25°C)

ID Code	L ¹ no load μH	I ^{2,4} rated A	L ³ at rated I μH	I ^{4,5} peak max A	R _{dc} at 25°C mΩ Max	Tol.
SESI 18 6K8 1WR	6.8	9.8	4.2	13.6	7.5	20
SESI 18 8K2 1WR	8.6	8.3	5.7	11.5	9.0	
SESI 18 11K 1WR	11	7.2	7.7	10	12	
SESI 18 15K 1WR	15	6.35	10.5	8.9	15	
SESI 18 18K 1WR	18	5.7	12.6	7.9	17	
SESI 18 22K 1WR	22	5.1	15.4	7.2	20	
SESI 18 22K 2WR	22.2	5.6	15.4	7.3	33	
SESI 18 27K 1WR	27	4.7	18.9	6.5	25	
SESI 18 37K 1WR	37	4.0	25.9	5.6	29	
SESI 18 49K 1WR	49	3.5	34.3	4.8	45	
SESI 18 56K 1WR	56	3.3	39	4.6	48	
SESI 18 70K 1WR	70	2.9	49	4.1	65	
SESI 18 86K 1WR	86	2.6	60	3.7	72	
SESI 18 M10 1WR	100	2.4	70	3.3	75	
SESI 18 M12 1WR	120	2.2	84	3.1	115	
SESI 18 M15 1WR	150	1.95	105	2.7	125	
SESI 18 M18 1WR	180	1.8	126	2.6	175	
SESI 18 M22 1WR	220	1.6	154	2.3	210	
SESI 18 M33 1WR	330	1.34	231	1.9	250	
SESI 18 M47 1WR	470	0.9	376	1.35	600	
						10

Notes

1. Inductance at 0.25 V, 100 kHz
2. I rated (permanent DC) can be increased on request depending on customer heat transfer
3. Typical inductance value at recommended full load
4. I peak max = maximum peak value of current at +125°C ; L value not guaranteed
5. 40 % admissible I ripple over I rated at f = 200 kHz
6. Isolation voltage 500 V_{DC}
- 1 min - Ri > 1 GΩ between winding and magnetic core

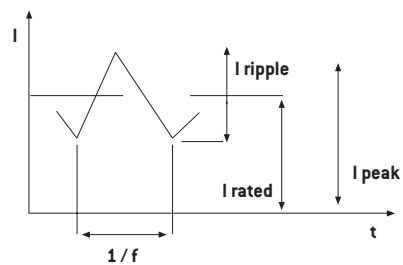

To Order

SESI	18	###	#	W	R
SMD Energy Storage Inductor	Size	Value code 4K9 = 4,9 μH M10 = 100 μH 1M0 = 1000 μH	Version	GW Terminals	High reliability

SESI 18 ### #WR

Connections

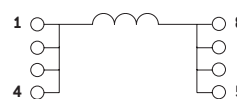

Marking

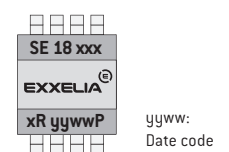

Packaging

Tape and Reel:
300 pieces per reel of diameter 330 mm

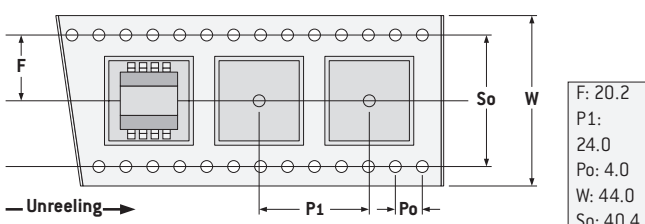

Dimensions

(mm, top view)

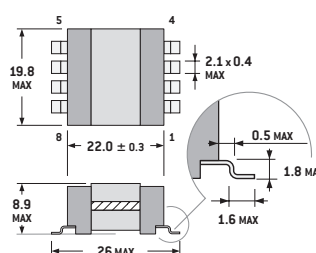

PCB Layout

(suggested)

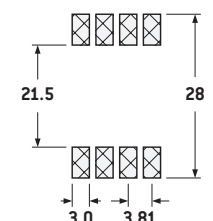

SESI Custom Technologies

Upon request our Engineers can design custom transformers and inductors in the standard SESI 9, 15, 18, 22 and 32 packages. These magnetics can be either surface mount or through-hole and can have up to 8 windings in the SESI 32 package.

This design approach offers faster response, no tooling cost and competitive prices because of low materials costs obtained from high-volume standard parts production.



Tape and Reel Dimensions

Platform	F (mm)	P1 (mm)	Po (mm)	W (mm)	So (mm)	Rel Ø (mm)	N° pieces
SESI 9.1 / 9.2	11.5	16.0	4.0	24	none	330	700
SESI 14SR	11.5	20.0	4.0	24	none	330	400
SESI 15SR	11.5	20.0	4.0	24	none	330	400
SESI 15WR	20.2	20.0	4.0	44.0	40.4	330	400
SESI 18	20.2	24.0	4.0	44.0	40.4	330	300
SESI 22	26.2	36.0	4.0	56.0	52.4	330	100

Packaging

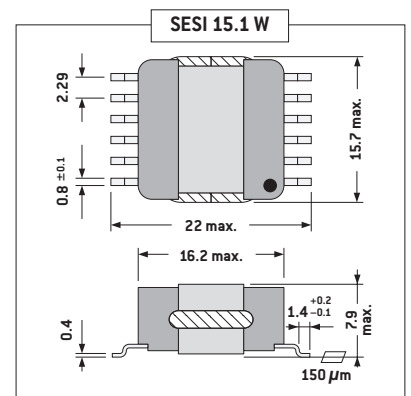
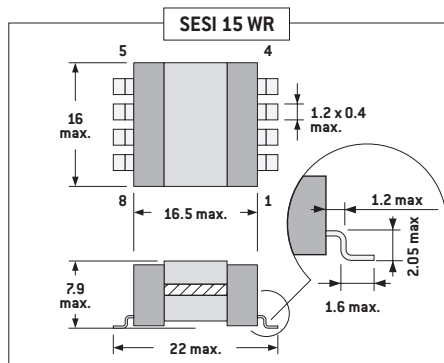
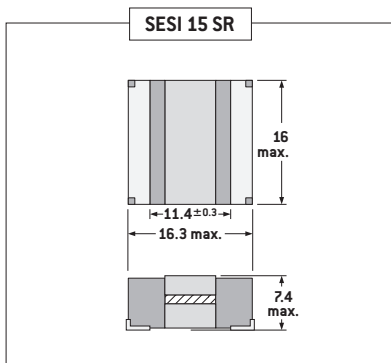
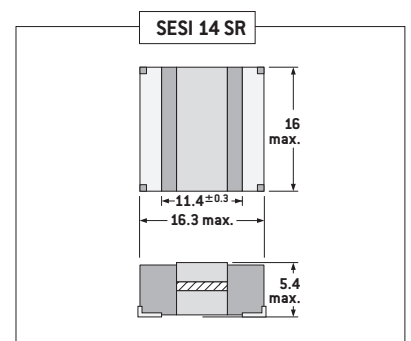
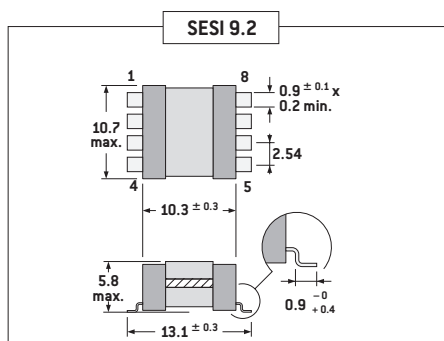
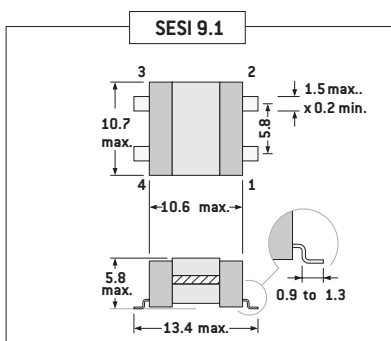
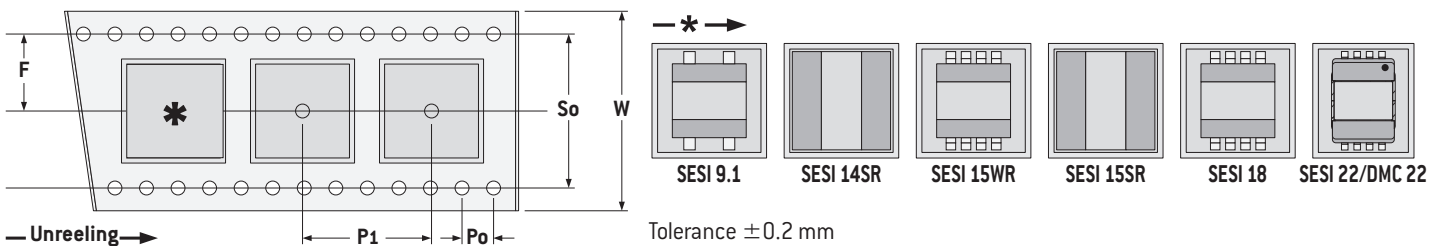

SESI Custom Technologies

HIGH GRADE TECHNOLOGY

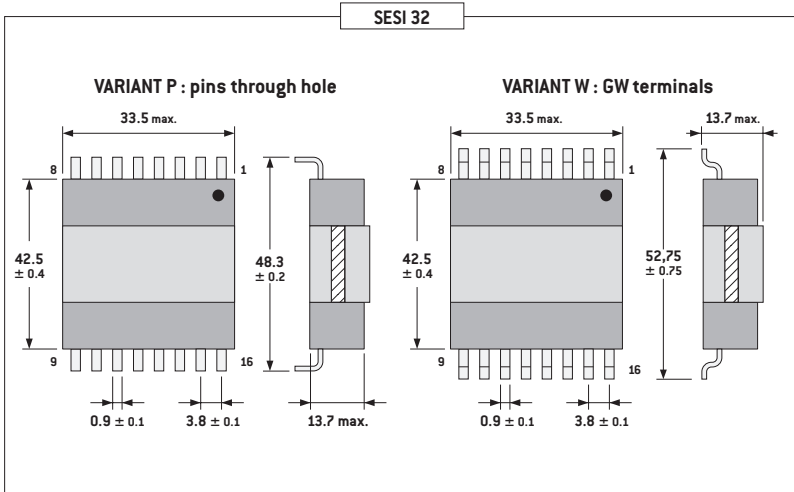
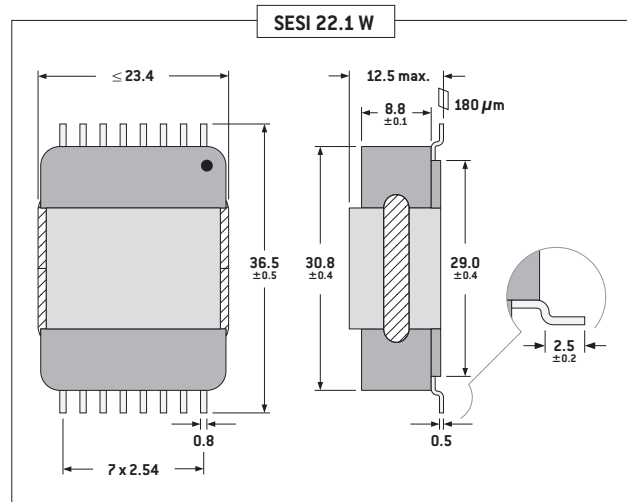
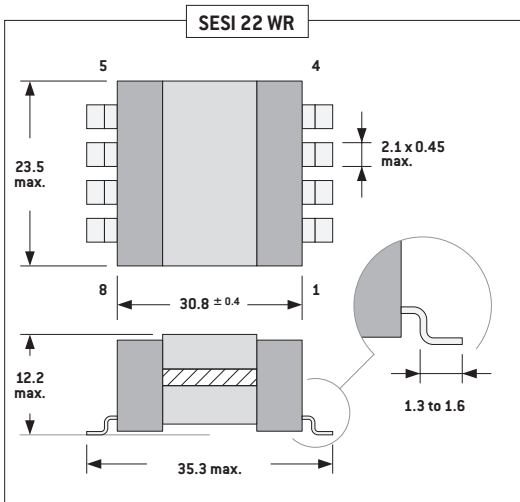
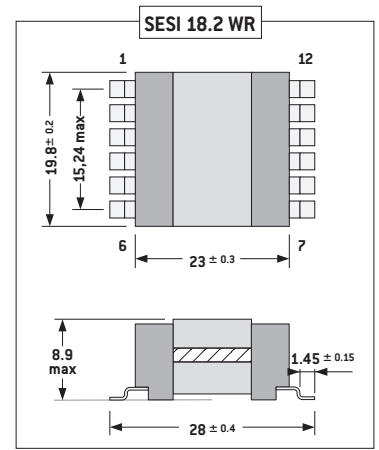
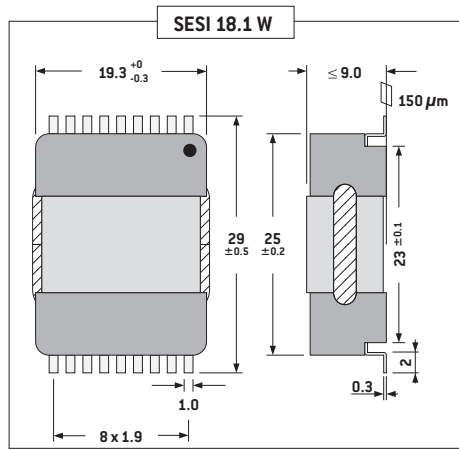
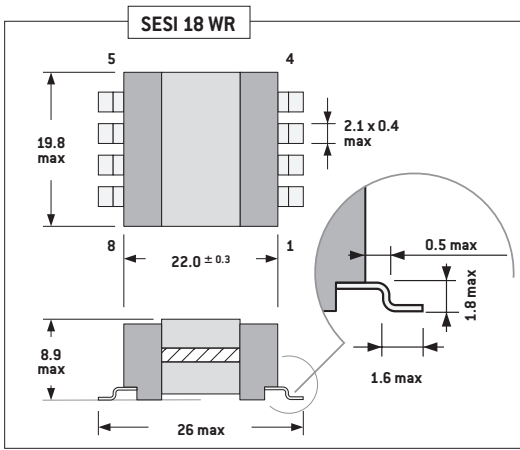

Shielded versions



SESI 15 WE



SESI 18.1 WE



SESI 22 WE



SESI 22.1 WE

Engineering Support

DESIGN CAPABILITIES

Exxelia designs magnetics for most applications:

- Switch-mode power supply including new and unusual architectures
- 360-800Hz Power supply (single and multipulse)
- 50 Hz power supply
- Current and Voltage measurement
- Lighting - Ignition
- Pulse transformer (gate drive, data)
- Micro inductor
- Audio-frequency
- Electromagnets etc.

Exxelia designs magnetics up to:

- 200kV dielectric strength
- 20kV operating voltage ...
- 240°C operating temperature

According to the main aerospace standards

- ESA ESCC 3201
- MIL-STD-981
- MIL-PRF-27
- DO-160 etc

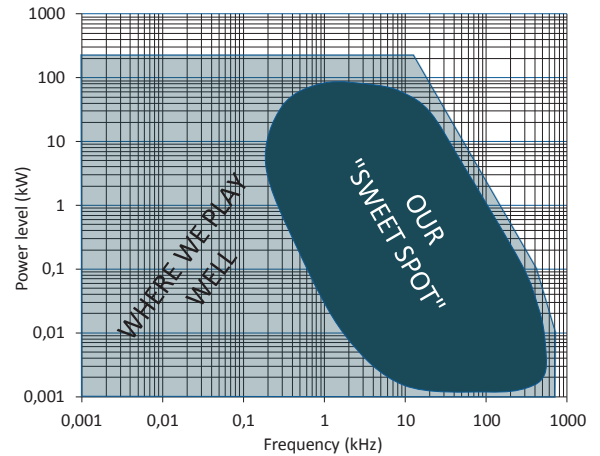

SWITCHED MODE POWE SUPPLY

Cross regulation in multi output Flyback converters

Exxelia has been working on this subject in order to understand the phenomenon, identify the cause(s) and find solutions to avoid the use of linear regulators consuming energy

The identification of a relevant magnetostatic model of the transformer and its electronic environment are necessary for analysis of the phenomenon into circuit simulation software like PSIM or PSPICE. This allows to evaluate the influence of the model parameters and the other components of the converter on the variability of output voltages.

The key point is then to link the product manufacturing technology to the parameters of the model, in order to reduce cross regulation thanks to the optimization of windings arrangement.

The work on this topic allows a precise control of the output voltages on the most sensitive windings.

Dual Active Bridge, small size & high efficiency

The dual active bridge is a topology more and more used to supply batteries because it allows bidirectional energy transfer with the network.

Exxelia is developing high reproducibility technology to integrate inductors in the transformer:

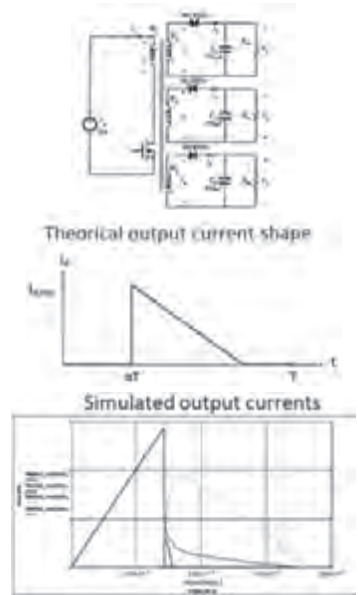

Example

3 Transformers in each power supply

Each transformer incorporates virtual inductance Lk

15 kW combined output @ 100 kHz switching

Taps provide flexibility for 350 V / 700 V input & 28 V or 56 V output (up to 430 A)

Exxelia value proposition: Small size, high efficiency, competitive cost despite multiple high current outputs and integrated inductors.

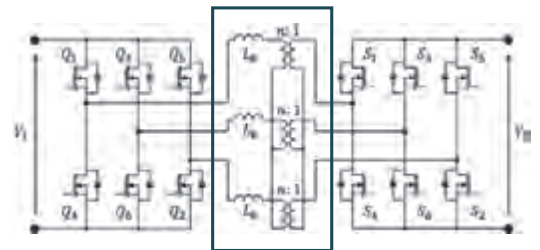

360-800Hz MULTI PULSE

Exxelia developed a specific knowledge to optimize the design of single and multi-pulse magnetics for 360 – 800 Hz power network.

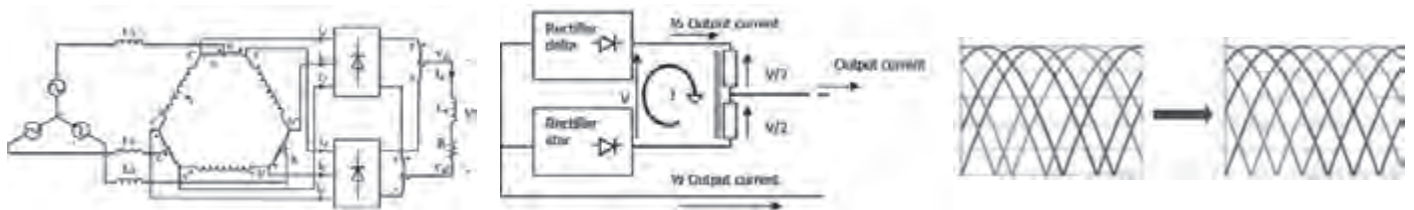

Global Optimization of the magnetics in the power supply Transformer/Autotransformer and Interphase Inductor

Consideration of limit operation conditions

Harmonic reduction thanks to losses management

ACCURATE MEASUREMENT TRANSFORMERS (0.1%) FOR CRITICAL APPLICATIONS

Real-time, detailed knowledge of the voltages and currents is becoming increasingly important to ensure the proper operation of electrical networks. This is as true for the aeronautics market as it is for the industrial market.

Measurement transformers, whether current or voltage, are sensors. They must faithfully transmit a signal level in a highly variable environment (excitation, frequency, temperature) which influences their characteristics.

Exxelia developed a designing method that takes into account all environmental conditions. The behavior of the sensor is modeled by a transfer function that depends on transformer characteristics and on the load resistance.

Depending on the application and the targeted accuracy, Exxelia defines the best operating point of the sensor by calculating the worst case errors with respect to the variability of the model parameters.

Exxelia designs sensors with an accuracy of up to 0.1%.

THERMAL MANAGEMENT, A PATH TO MINIATURIZATION

For Exxelia, better thermal management translates into miniaturization of the component.

Indeed, thanks to an accurate calculation of the maximum operating temperature, Exxelia can design the smallest component able to transfer a given power.

The calculation of this temperature requires the knowledge of the heating sources (core and copper losses) and the component thermal behavior.

Exxelia uses a calculation method to do the best use of core losses data and improve them by developing partnership with core manufacturer

The copper losses due to Eddy current are taken into account by Exxelia through the identification of the overriding causes and the use of the most relevant analytical approaches to evaluate them.

The calculation of the operating temperature from the losses requires to determine the thermal resistance, which varies according to the ambient temperature, the power dissipated and the exchange conditions with the environment.

Exxelia performs measurement campaigns to determine the thermal resistances and their variation for its qualified technologies and for most of the standard ferrite shapes. In particular, the influence of natural convection is taken into account to address products for Space.

When more detailed analysis is required, Exxelia has developed a unique thermal simulation software, based on finite element calculation and dedicated to magnetic components to make its use easier and faster.

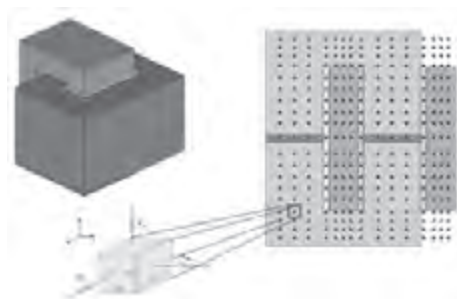

Finite element analysis

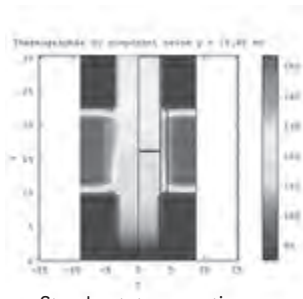

Steady state operating temperature calculation

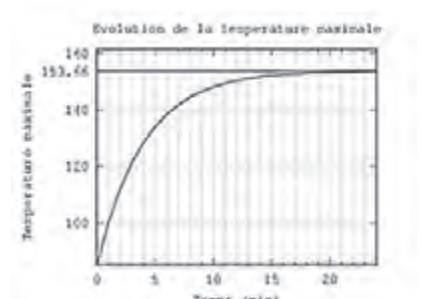

Transient

HIGH VOLTAGE AND ELECTRIC FIELD CALCULATION

Exxelia developed specific design skills to anticipate voltage increase requested for aircraft and space embedded application. High voltage topic is mastered with both dedicated test equipment (up to 100kV) and electric field calculation knowhow.

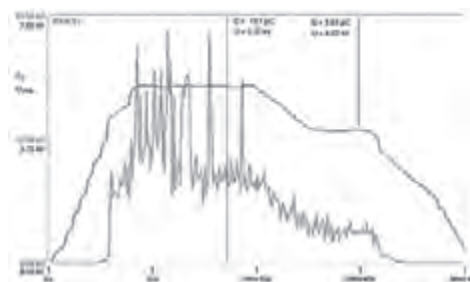

Partial discharge equipment available up to 100kV

Engineering Support

Electric Field mitigation: In high voltage applications, local high electric field E [kV/mm] can lead to a premature aging of insulating parts or insulators? (Partial discharge) and finally to an electric failure.

Simulation in the design phase, using finite element calculations with a 2D or 3D electrostatic software allows Exxelia to reduce high field areas and increase lifetime.

Example: Electric Field, Iso-Voltage values



Custom High Voltage Transformer

ELECTROMECHANICAL DEVICES

Exxelia engineers use advanced finite-elements simulation software to model and analyse electromagnetic behaviour.

EXXELIA can provide a high added-value support for electromechanical devices optimization through electromagnetic and thermal calculations (weight reduction, torque increase, losses reduction, etc...):

- 2D and 3D calculations:
 - Magnetostatic: B [T], J [A/mm²], L matrix (function of current)
 - Electrostatic: E [kV/mm], C matrix
 - Eddy current (AC) in magneto-harmonic
 - 2D transient coupled multiphysics (electric + magnetic + circuit)
- Specific analysis:
 - Optimization under constraints
 - Parametric analysis
 - Sensitivity analysis



CAD geometry and circuit import/export (step, Catia, Spice, ...)

Some calculations: Torque [N.m], Force [N], Resistance [Ω], Losses [W], L matrix [H], C matrix [F]

Some applications: linear or angular electric motor, electromagnet, linear or angular actuator, proportional valves, position sensor, etc... Proportional Hydraulic Valve

Topology analysis: Based on an extensive experience, Exxelia can offer the best topology dedicated to an application or look for the best performance within a given space:

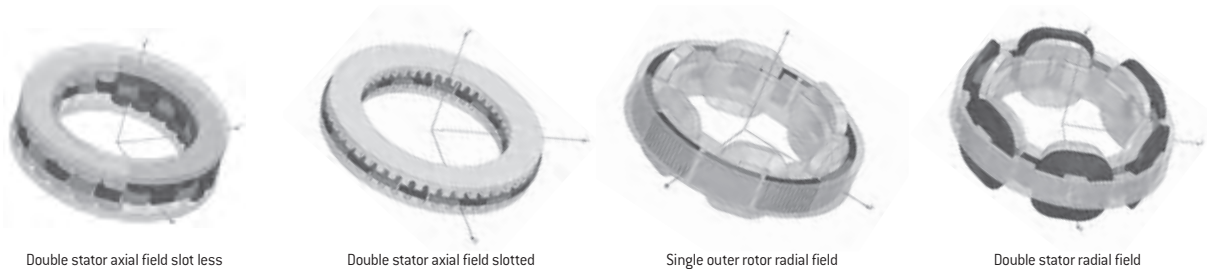

Torque, field and geometrical optimization

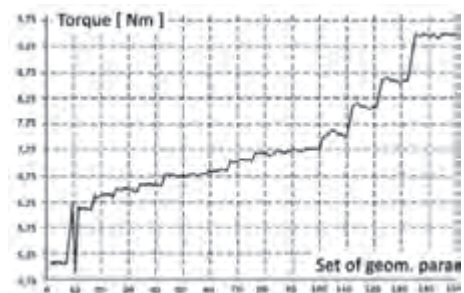

SMD Power Inductors

SESI xx



SESI series are usually installed on Military applications and breadboards for Space applications.

Since January 2003, EXXELIA has been manufacturing Radio Frequency Fixed Coils, SESI series fulfilling ESA ESCC Generic specification N° 3201 and detail specification N° 3201/009.

This qualification approval includes final production tests Chart F2, burn-in and electrical measurements to testing Chart F3 and qualification testing Chart F4.

For procurement, different quality levels are offered:

- Final production tests Chart F2
- Burn-in and electrical measurements Chart F3
- Lot acceptance testing Chart F4 if required

Components delivered through this specification need to be processed and inspected in accordance with the EXXELIA Process Identification Document (P.I.D.).

Each component delivered is traceable to its production lot. The finish will be Sn60Pb40.

Cross reference chart

EXXELIA Non-QPL ID Code	ESA SCC Component Part Number
SESI 9.1 1K0 1WR	3201009 05 1L0 N
SESI 9.1 1K5 1WR	3201009 05 1L5 N
SESI 9.1 2K0 2WR	3201009 05 2L0 N
SESI 9.1 2K6 2WR	3201009 05 2L6 M
SESI 9.1 3K4 2WR	3201009 05 3L4 M
SESI 9.1 4K3 2WR	3201009 05 4L3 M
SESI 9.1 6K2 2WR	3201009 05 6L2 M
SESI 9.1 8K5 2WR	3201009 05 8L5 M
SESI 9.1 10K 2WR	3201009 05 100 M
SESI 9.1 15K 2WR	3201009 05 150 M
SESI 9.1 18K 2WR	3201009 05 180 M
SESI 9.1 22K 2WR	3201009 05 220 M
SESI 9.1 26K 2WR	3201009 05 260 M
SESI 9.1 33K 2WR	3201009 05 330 K
SESI 9.1 47K 2WR	3201009 05 470 K
SESI 9.1 66K 2WR	3201009 05 660 K
SESI 9.1 81K 2WR	3201009 05 810 K
SESI 9.1 M10 2WR	3201009 05 101 K
SESI 9.1 M15 1WR	3201009 05 151 K
SESI 9.1 M22 1WR	3201009 05 221 K
SESI 9.1 M33 1WR	3201009 05 331 K
SESI 9.1 M47 1WR	3201009 05 471 K
SESI 9.1 M68 1WR	3201009 05 681 K
SESI 9.1 M10 1WR	3201009 05 102 K
3201009 05 ### y	
Tolerance:	
y = N for ±30%	
y = M for ±20%	
y = K for ±10%	

Cross reference chart

EXXELIA Non-QPL ID Code	ESA SCC Component Part Number
SESI 14 3K3 1SR	3201009 01 3L3 M
SESI 14 4K7 1SR	3201009 01 4L7 M
SESI 14 6K0 1SR	3201009 01 6L0 M
SESI 14 8K2 1SR	3201009 01 8L2 M
SESI 14 10K 1SR	3201009 01 100 M
SESI 14 15K 1SR	3201009 01 150 M
SESI 14 22K 1SR	3201009 01 220 M
SESI 14 33K 1SR	3201009 01 330 M
SESI 14 47K 1SR	3201009 01 470 K
SESI 14 56K 1SR	3201009 01 560 K
SESI 14 68K 1SR	3201009 01 680 K
SESI 14 82K 1SR	3201009 01 820 K
SESI 14 M10 1SR	3201009 01 101 K
SESI 14 M12 1SR	3201009 01 121 K
SESI 14 M15 1SR	3201009 01 151 K
SESI 14 M18 1SR	3201009 01 181 K
SESI 14 M22 1SR	3201009 01 221 K
SESI 14 M33 1SR	3201009 01 331 K
3201009 01 ### y	
Tolerance:	
y = M for ±20%	
y = K for ±10%	

Cross reference chart

EXXELIA Non-QPL ID Code	ESA SCC Component Part Number
SESI 15 1K5 2SR	3201009 02 1L5 N
SESI 15 1K8 1SR	3201009 02 1L8 N
SESI 15 2K7 1SR	3201009 02 2L7 M
SESI 15 4K9 1SR	3201009 02 4L9 M
SESI 15 6K4 1SR	3201009 02 6L4 M
SESI 15 8K0 1SR	3201009 02 8L0 M
SESI 15 12K 1SR	3201009 02 120 M
SESI 15 16K 1SR	3201009 02 160 M
SESI 15 18K 1SR	3201009 02 180 M
SESI 15 21K 1SR	3201009 02 210 M
SESI 15 27K 1SR	3201009 02 270 M
SESI 15 33K 1SR	3201009 02 330 M
SESI 15 48K 1SR	3201009 02 480 K
SESI 15 56K 1SR	3201009 02 560 K
SESI 15 68K 1SR	3201009 02 680 K
SESI 15 82K 1SR	3201009 02 820 K
SESI 15 M10 1SR	3201009 02 101 K
SESI 15 M12 1SR	3201009 02 121 K
SESI 15 M15 1SR	3201009 02 151 K
SESI 15 M22 1SR	3201009 02 221 K
SESI 15 M33 1SR	3201009 02 331 K
SESI 15 M10 1SR	3201009 02 102 K
SESI 15 2M3 1SR	3201009 02 232 K
3201009 02 ### y	
Tolerance:	
y = N for ±30%	
y = M for ±20%	
y = K for ±10%	

SMD Power Inductors

SESI xx



Cross reference chart

EXXELIA Non-QPL ID Code	ESA SCC Component Part Number
SESI 15 1K5 2WR	3201009 03 1L5 N
SESI 15 1K8 1WR	3201009 03 1L8 N
SESI 15 2K7 1WR	3201009 03 2L7 M
SESI 15 4K9 1WR	3201009 03 4L9 M
SESI 15 6K4 1WR	3201009 03 6L4 M
SESI 15 8K0 1WR	3201009 03 8L0 M
SESI 15 12K 1WR	3201009 03 120 M
SESI 15 16K 1WR	3201009 03 160 M
SESI 15 18K 1WR	3201009 03 180 M
SESI 15 21K 1WR	3201009 03 210 M
SESI 15 27K 1WR	3201009 03 270 M
SESI 15 33K 1WR	3201009 03 330 M
SESI 15 48K 1WR	3201009 03 480 K
SESI 15 56K 1WR	3201009 03 560 K
SESI 15 68K 1WR	3201009 03 680 K
SESI 15 82K 1WR	3201009 03 820 K
SESI 15 M10 1WR	3201009 03 101 K
SESI 15 M12 1WR	3201009 03 121 K
SESI 15 M15 1WR	3201009 03 151 K
SESI 15 M22 1WR	3201009 03 221 K
SESI 15 M33 1WR	3201009 03 331 K
SESI 15 1M0 1WR	3201009 03 102 K
SESI 15 2M3 1WR	3201009 03 232 K

3201009 03 ### y

Tolerance:
y = N for $\pm 30\%$
y = M for $\pm 20\%$
y = K for $\pm 10\%$

Cross reference chart

EXXELIA Non-QPL ID Code	ESA SCC Component Part Number
SESI 18 6K8 1WR	3201009 04 6L8 M
SESI 18 8K2 1WR	3201009 04 8L2 M
SESI 18 11K 1WR	3201009 04 110 M
SESI 18 15K 1WR	3201009 04 150 M
SESI 18 18K 1WR	3201009 04 180 M
SESI 18 22K 1WR	3201009 04 220 M
SESI 18 27K 1WR	3201009 04 270 M
SESI 18 37K 1WR	3201009 04 370 K
SESI 18 49K 1WR	3201009 04 490 K
SESI 18 56K 1WR	3201009 04 560 K
SESI 18 70K 1WR	3201009 04 700 K
SESI 18 86K 1WR	3201009 04 860 K
SESI 18 M10 1WR	3201009 04 101 K
SESI 18 M12 1WR	3201009 04 121 K
SESI 18 M15 1WR	3201009 04 151 K
SESI 18 M18 1WR	3201009 04 181 K
SESI 18 M22 1WR	3201009 04 221 K
SESI 18 M33 1WR	3201009 04 331 K

3201009 04 ### y

Tolerance:
y = M for $\pm 20\%$
y = K for $\pm 10\%$

Cross reference chart

EXXELIA Non-QPL ID Code	ESA SCC Component Part Number
SESI 22 7K0 2WR	3201009 06 7L0 M
SESI 22 7K7 2WR	3201009 06 7L7 M
SESI 22 10K 2WR	3201009 06 100 M
SESI 22 13K 2WR	3201009 06 130 M
SESI 22 19K 2WR	3201009 06 190 M
SESI 22 24K 2WR	3201009 06 240 M
SESI 22 33K 2WR	3201009 06 330 M
SESI 22 47K 1WR	3201009 06 470 K
SESI 22 64K 1WR	3201009 06 640 K
SESI 22 82K 1WR	3201009 06 820 K
SESI 22 M10 1WR	3201009 06 101 K
SESI 22 M15 1WR	3201009 06 151 K
SESI 22 M21 1WR	3201009 06 211 K
SESI 22 M34 1WR	3201009 06 341 K
SESI 22 M47 1WR	3201009 06 471 K
SESI 22 M68 1WR	3201009 06 681 K
SESI 22 M82 1WR	3201009 06 821 K
SESI 22 1M0 1WR	3201009 06 102 K
SESI 22 1M5 1WR	3201009 06 152 K
SESI 22 2M2 1WR	3201009 06 222 K

3201009 06 ### y

Tolerance:
y = M for $\pm 20\%$
y = K for $\pm 10\%$

Cross reference chart

EXXELIA Non-QPL ID Code	ESA SCC Component Part Number
SESI 32 4K9 1WR	3201009 07 4L9 N
SESI 32 12K 1WR	3201009 07 120 N
SESI 32 22K 1WR	3201009 07 220 N
SESI 32 36K 1WR	3201009 07 360 M
SESI 32 53K 1WR	3201009 07 530 M
SESI 32 73K 1WR	3201009 07 730 K
SESI 32 84K 1WR	3201009 07 840 K
SESI 32 M11 1WR	3201009 07 111 K
SESI 32 M15 1WR	3201009 07 151 K
SESI 32 M20 1WR	3201009 07 201 K
SESI 32 M26 1WR	3201009 07 261 K
SESI 32 M35 1WR	3201009 07 351 K
SESI 32 M45 1WR	3201009 07 451 K
SESI 32 M62 1WR	3201009 07 621 K
SESI 32 M83 1WR	3201009 07 831 K
SESI 32 1M0 1WR	3201009 07 102 K
SESI 32 2M0 1WR	3201009 07 202 K
SESI 32 4M7 1WR	3201009 07 472 K

3201009 07 ### y

Tolerance:
y = M for $\pm 20\%$
y = K for $\pm 10\%$
y = N for $\pm 30\%$

Cross reference chart

EXXELIA Non-QPL ID Code	ESA SCC Component Part Number
SESI 32 4K9 1PR	3201009 08 4L9 N
SESI 32 12K 1PR	3201009 08 120 N
SESI 32 22K 1PR	3201009 08 220 N
SESI 32 36K 1PR	3201009 08 360 M
SESI 32 53K 1PR	3201009 08 530 M
SESI 32 73K 1PR	3201009 08 730 K
SESI 32 84K 1PR	3201009 08 840 K
SESI 32 M11 1PR	3201009 08 111 K
SESI 32 M15 1PR	3201009 08 151 K
SESI 32 M20 1PR	3201009 08 201 K
SESI 32 M26 1PR	3201009 08 261 K
SESI 32 M35 1PR	3201009 08 351 K
SESI 32 M45 1PR	3201009 08 451 K
SESI 32 M62 1PR	3201009 08 621 K
SESI 32 M83 1PR	3201009 08 831 K
SESI 32 1M0 1PR	3201009 08 102 K
SESI 32 2M0 1PR	3201009 08 202 K
SESI 32 4M7 1PR	3201009 08 472 K

3201009 07 ### y

Tolerance:
y = M for $\pm 20\%$
y = K for $\pm 10\%$
y = N for $\pm 30\%$