

Miniature Chip Inductors MPCI 20000 Series



Electrical Data (25°C)

ID Code	Induct. μH	Q Min	Q Typ.	Test Freq. MHz	SFR Min. MHz	R _{DC} max. Ω	DC Curr. mA max	Tol %
MPCI 20 000 010	0.010	60	65	150	2000	0.04	1000	
MPCI 20 000 012	0.012	70	82	150	1800	0.04	1000	
MPCI 20 000 015	0.015	75	87	150	1500	0.04	1000	
MPCI 20 000 018	0.018	75	87	150	1500	0.04	1000	
MPCI 20 000 022	0.022	60	65	100	1300	0.05	1000	
MPCI 20 000 027	0.027	60	70	100	1300	0.05	1000	
MPCI 20 000 033	0.033	60	70	100	1000	0.05	1000	
MPCI 20 000 039	0.039	60	70	100	1000	0.06	900	
MPCI 20 000 047	0.047	65	75	100	800	0.06	900	
MPCI 20 000 056	0.056	65	75	100	760	0.06	900	
MPCI 20 000 068	0.068	65	75	100	700	0.07	840	
MPCI 20 000 082	0.082	65	75	100	650	0.07	840	
MPCI 20 000 100	0.100	65	77	50	570	0.07	840	
MPCI 20 000 120	0.120	65	77	50	520	0.07	840	
MPCI 20 000 150	0.150	75	87	50	400	0.08	790	
MPCI 20 000 180	0.180	75	87	50	360	0.08	790	
MPCI 20 000 220	0.220	70	80	50	320	0.08	790	
MPCI 20 000 270	0.270	70	80	50	270	0.10	700	
MPCI 20 000 330	0.330	70	80	50	240	0.10	700	
MPCI 20 000 390	0.390	70	80	50	220	0.10	700	
MPCI 20 000 470	0.470	70	80	25	190	0.14	590	
MPCI 20 000 560	0.560	70	82	25	170	0.19	510	
MPCI 20 000 680	0.680	70	83	25	160	0.26	430	
MPCI 20 000 820	0.820	75	84	25	150	0.30	400	
MPCI 20 001 000	1.00	75	87	25	130	0.34	380	
MPCI 20 001 200	1.20	65	73	7.9	120	0.45	330	
MPCI 20 001 500	1.50	65	73	7.9	110	0.57	290	
MPCI 20 001 800	1.80	65	73	7.9	100	0.72	260	
MPCI 20 002 200	2.20	65	73	7.9	80	0.9	230	
MPCI 20 002 700	2.70	65	73	7.9	60	1.1	210	
MPCI 20 003 300	3.30	60	70	7.9	50	1.2	200	
MPCI 20 003 900	3.90	60	70	7.9	45	1.4	180	
MPCI 20 004 700	4.70	60	70	7.9	42	1.6	170	
MPCI 20 005 600	5.60	65	75	7.9	40	1.8	160	
MPCI 20 006 800	6.80	65	75	7.9	37	2.4	140	

10

- Cesa qualified 3201/008 and in accordance to Mil Spec M83446/10
- Excellent Q values even at high frequencies
- Very high self-resonant frequencies (SFRs)
- Extremely stable inductance values from -55°C to +125°C
- With or without tab terminations
- Tin / lead or gold plated terminations
- Frequency range: 790 kHz to 500 MHz
- Operating temperature range: -55°C to +125°C
- Weight: 0.15 gram • MSL level: 1

ID Code	Induct. μH	Q Min	Q Typ.	Test Freq. MHz	SFR Min. MHz	R _{DC} max. Ω	DC Curr. mA max	Tol % Min
MPCI 20 008	8.20	65	75	7.9	34	3.0	130	
MPCI 20 010 000	10.0	65	75	7.9	29	3.5	120	
MPCI 20 012 000	12.0	60	70	2.5	27	3.6	118	
MPCI 20 015 000	15.0	60	70	2.5	22	3.7	115	
MPCI 20 018 000	18.0	60	72	2.5	17	3.8	114	
MPCI 20 022 000	22.0	60	72	2.5	16	3.9	113	
MPCI 20 027 000	27.0	65	75	2.5	15	4.0	110	
MPCI 20 033 000	33.0	65	75	2.5	14	5.0	100	
MPCI 20 039 000	39.0	65	75	2.5	13	7.0	84	
MPCI 20 047 000	47.0	70	78	2.5	12	8.0	79	
MPCI 20 056 000	56.0	70	78	2.5	11	10.0	70	
MPCI 20 068 000	68.0	65	75	2.5	10	11.0	67	
MPCI 20 082 000	82.0	60	72	2.5	9	12.0	64	
MPCI 20 100 000	100.0	60	70	2.5	8	13.0	62	
MPCI 20 120 000	120.0	40	48	0.79	7	14.0	59	
MPCI 20 150 000	150.0	40	48	0.79	6	16.0	56	
MPCI 20 180 000	180.0	40	48	0.79	5	18.0	52	
MPCI 20 220 000	220.0	40	48	0.79	4	24.0	45	
MPCI 20 270 000	270.0	40	48	0.79	3.3	25.0	44	
MPCI 20 330 000	330.0	40	48	0.79	3.1	29.0	41	
MPCI 20 390 000	390.0	40	48	0.79	2.9	32.0	39	
MPCI 20 470 000	470.0	35	45	0.79	2.4	35.0	37	
MPCI 20 560 000	560.0	35	45	0.79	2.1	45.0	33	
MPCI 20 680 000	680.0	35	40	0.79	1.9	55.0	30	
MPCI 20 820 000	820.0	30	36	0.79	1.8	70.0	26	
MPCI 20 1000 000	1000.0	30	36	0.79	1.7	80.0	25	

10

Other inductance values on request.

Inductance variation: 60 PPM /°C max. in the range 0.01 to 1 μH
 80 PPM /°C max. in the range 1.2 to 10 μH
 150 PPM /°C max. in the range 12 to 100 μH
 300 PPM /°C max. in the range 120 to 1000 μH

Packaging

Tape and Reel (with or without tab): 100 to 500 pieces or Tray: 49 pieces

Typical Dimensions (mm)

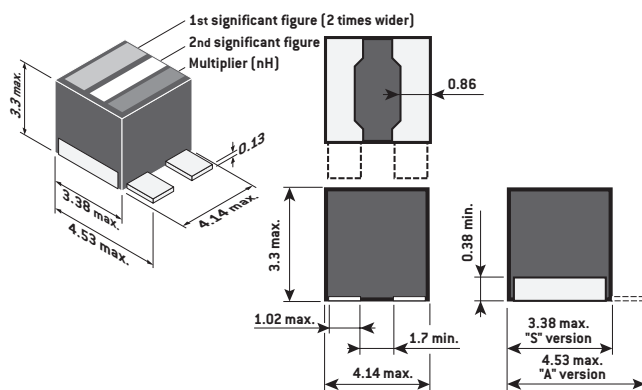

Q vs frequency

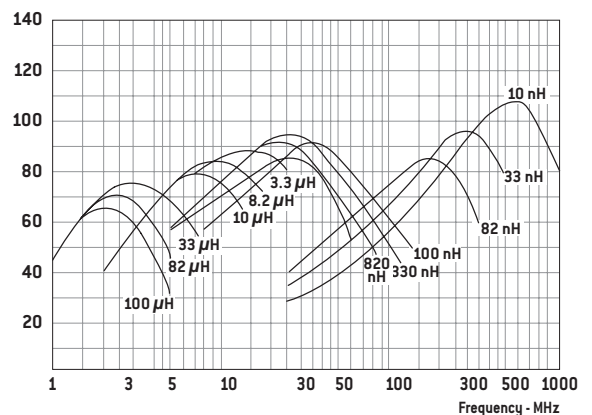

Miniature Chip Inductors MSCI 20000 Series



MPCI 20000 series are usually installed on Military applications and breadboards for Space applications.

Since January 2003, EXXELIA has been manufacturing Radio Frequency Fixed Coils, MPCI 20000 series fulfilling ESA ESCC Generic specification N° 3201 and detail specification N° 3201/008.

This range is named MSCI (S for space applications).

This qualification approval includes final production tests Chart F2, burn-in and electrical measurements to testing Chart F3 and qualification testing Chart F4.

For procurement, different quality levels are offered:

- Final production tests Chart F2
- Burn-in and electrical measurements Chart F3
- Lot acceptance testing Chart F4 if required

Components delivered through this specification need to be processed and inspected in accordance with the EXXELIA Process Identification Document (P.I.D.).

Each component delivered is traceable to its production lot.

Cross reference chart

EXXELIA ID Code *MPCI (Non-QPL) * MSCI (QPL)	ESA SCC Component Part Number	In accordance to MIL-PRF-83446 Part Number	
		** Tin lead (F) or ** Gold lead (A) with tab	** Tin lead (F) or ** Gold lead (A) without tab
* 20 000 010 x y 10	3201008 aa L010 K	M83446/10-01**	M83446/10-62**
* 20 000 012 x y 10	3201008 aa L012 K	M83446/10-02**	M83446/10-63**
* 20 000 015 x y 10	3201008 aa L015 K	M83446/10-03**	M83446/10-64**
* 20 000 018 x y 10	3201008 aa L018 K	M83446/10-04**	M83446/10-65**
* 20 000 022 x y 10	3201008 aa L022 K	M83446/10-05**	M83446/10-66**
* 20 000 027 x y 10	3201008 aa L027 K	M83446/10-06**	M83446/10-67**
* 20 000 033 x y 10	3201008 aa L033 K	M83446/10-07**	M83446/10-68**
* 20 000 039 x y 10	3201008 aa L039 K	M83446/10-08**	M83446/10-69**
* 20 000 047 x y 10	3201008 aa L047 K	M83446/10-09**	M83446/10-70**
* 20 000 056 x y 10	3201008 aa L056 K	M83446/10-10**	M83446/10-71**
* 20 000 068 x y 10	3201008 aa L068 K	M83446/10-11**	M83446/10-72**
* 20 000 082 x y 10	3201008 aa L082 K	M83446/10-12**	M83446/10-73**
* 20 000 100 x y 10	3201008 aa L10 K	M83446/10-13**	M83446/10-74**
* 20 000 120 x y 10	3201008 aa L12 K	M83446/10-14**	M83446/10-75**
* 20 000 150 x y 10	3201008 aa L15 K	M83446/10-15**	M83446/10-76**
* 20 000 180 x y 10	3201008 aa L18 K	M83446/10-16**	M83446/10-77**
* 20 000 220 x y 10	3201008 aa L22 K	M83446/10-17**	M83446/10-78**
* 20 000 270 x y 10	3201008 aa L27 K	M83446/10-18**	M83446/10-79**
* 20 000 330 x y 10	3201008 aa L33 K	M83446/10-19**	M83446/10-80**
* 20 000 390 x y 10	3201008 aa L39 K	M83446/10-20**	M83446/10-81**
* 20 000 470 x y 10	3201008 aa L47 K	M83446/10-21**	M83446/10-82**
* 20 000 560 x y 10	3201008 aa L56 K	M83446/10-22**	M83446/10-83**
* 20 000 680 x y 10	3201008 aa L68 K	M83446/10-23**	M83446/10-84**
* 20 000 820 x y 10	3201008 aa L82 K	M83446/10-24**	M83446/10-85**
* 20 001 000 x y 10	3201008 aa 1L0 K	M83446/10-25**	M83446/10-86**
* 20 001 200 x y 10	3201008 aa 1L2 K	M83446/10-26**	M83446/10-87**
* 20 001 500 x y 10	3201008 aa 1L5 K	M83446/10-27**	M83446/10-88**
* 20 001 800 x y 10	3201008 aa 1L8 K	M83446/10-28**	M83446/10-89**
* 20 002 200 x y 10	3201008 aa 2L2 K	M83446/10-29**	M83446/10-90**
* 20 002 700 x y 10	3201008 aa 2L7 K	M83446/10-30**	M83446/10-91**
* 20 003 300 x y 10	3201008 aa 3L3 K	M83446/10-31**	M83446/10-92**
* 20 003 900 x y 10	3201008 aa 3L9 K	M83446/10-32**	M83446/10-93**
* 20 004 700 x y 10	3201008 aa 4L7 K	M83446/10-33**	M83446/10-94**

EXXELIA ID Code *MPCI (Non-QPL) *MPCI (QPL)	ESA SCC Component Part Number	In accordance to MIL-PRF-83446 Part Number	
		** Tin lead (F) or ** Gold lead (A) with tab	** Tin lead (F) or ** Gold lead (A) without tab
* 20 005 600 x y 10	3201008 aa 5L6 K	M83446/10-34**	M83446/10-95**
* 20 006 800 x y 10	3201008 aa 6L8 K	M83446/10-35**	M83446/10-96**
* 20 008 200 x y 10	3201008 aa 8L2 K	M83446/10-36**	M83446/10-97**
* 20 010 000 x y 10	3201008 aa 100 K	M83446/10-37**	M83446/10-98**
* 20 012 000 x y 10	3201008 aa 120 K	M83446/10-38**	M83446/10-99**
* 20 015 000 x y 10	3201008 aa 150 K	M83446/10-39**	M83446/10-100**
* 20 018 000 x y 10	3201008 aa 180 K	M83446/10-40**	M83446/10-101**
* 20 022 000 x y 10	3201008 aa 220 K	M83446/10-41**	M83446/10-102**
* 20 027 000 x y 10	3201008 aa 270 K	M83446/10-42**	M83446/10-103**
* 20 033 000 x y 10	3201008 aa 330 K	M83446/10-43**	M83446/10-104**
* 20 039 000 x y 10	3201008 aa 390 K	M83446/10-44**	M83446/10-105**
* 20 047 000 x y 10	3201008 aa 470 K	M83446/10-45**	M83446/10-106**
* 20 056 000 x y 10	3201008 aa 560 K	M83446/10-46**	M83446/10-107**
* 20 068 000 x y 10	3201008 aa 680 K	M83446/10-47**	M83446/10-108**
* 20 082 000 x y 10	3201008 aa 820 K	M83446/10-48**	M83446/10-109**
* 20 100 000 x y 10	3201008 aa 101 K	M83446/10-49**	M83446/10-110**
* 20 120 000 x y 10	3201008 aa 121 K	M83446/10-50**	M83446/10-111**
* 20 150 000 x y 10	3201008 aa 151 K	M83446/10-51**	M83446/10-112**
* 20 180 000 x y 10	3201008 aa 181 K	M83446/10-52**	M83446/10-113**
* 20 220 000 x y 10	3201008 aa 221 K	M83446/10-53**	M83446/10-114**
* 20 270 000 x y 10	3201008 aa 271 K	M83446/10-54**	M83446/10-115**
* 20 330 000 x y 10	3201008 aa 331 K	M83446/10-55**	M83446/10-116**
* 20 390 000 x y 10	3201008 aa 391 K	M83446/10-56**	M83446/10-117**
* 20 470 000 x y 10	3201008 aa 471 K	M83446/10-57**	M83446/10-118**
* 20 560 000 x y 10	3201008 aa 561 K	M83446/10-58**	M83446/10-119**
* 20 680 000 x y 10	3201008 aa 681 K	M83446/10-59**	M83446/10-120**
* 20 820 000 x y 10	3201008 aa 821 K	M83446/10-60**	M83446/10-121**
* 20 1000 000 x y 10	3201008 aa 102 K	M83446/10-61**	M83446/10-122**

aa	K/J/G (tolerance)
aa = 03	K for ±10%
for Au Termination	J for ±5%
aa = 04	G for ±2%
for SnPb Termination	

HIGH GRADE PRODUCTS

To Order

MPCI 20 ### ## x y 10

MPCI	20	#####	x	y	z
Radio Frequency Fixed Coils	Size	Inductance Value (nH) from 000 010 to 010 000	Terminations x = T for SnPb x = G for Gold	Terminations shape y = S without tab y = A with tab (Not valid for space use)	Tolerance: 10 for ±10%