

Miniature Chip Inductors MPCI 12000 Series



- eesa qualified 3201/008 and in accordance to Mil Spec M83446/6
- Excellent Q values even at high frequencies
- Very high self-resonant frequencies (SFRs)
- Extremely stable inductance values from -55°C to +125°C
- With or without tab terminations
- Tin / lead or gold plated terminations
- Frequency range: 790 kHz to 30 MHz
- Operating temperature range: -55°C to +125°C
- Weight: 0.07 gram
- MSL level: 1

Electrical Data (25°C)

ID Code	Inductance* μ H	Q Min	Test Freq. MHz	SFR Min. MHz	R _{DC} max. Ω	DC Current mA max	Tol** %
MPCI 12 012 000	12	42	2.5	26	2.0	110	2 5-10
MPCI 12 015 000	15	44	2.5	24	2.2	105	
MPCI 12 018 000	18	44	2.5	21	2.8	100	
MPCI 12 022 000	22	48	2.5	20	3.5	85	
MPCI 12 027 000	27	49	2.5	19	4.3	75	
MPCI 12 033 000	33	50	2.5	14	5.5	68	
MPCI 12 039 000	39	52	2.5	12	6.5	61	
MPCI 12 047 000	47	53	2.5	11	8.5	54	
MPCI 12 056 000	56	56	2.5	10	12	46	
MPCI 12 068 000	68	53	2.5	9.0	13	42	
MPCI 12 082 000	82	49	2.5	8.0	15	40	
MPCI 12 100 000	100	49	2.5	7.0	18	36	
MPCI 12 120 000	120	37	0.79	6.0	21	34	
MPCI 12 150 000	150	30	0.79	5.0	26	31	
MPCI 12 180 000	180	30	0.79	5.0	28	29	
MPCI 12 220 000	220	26	0.79	4.5	32	29	

ID Code	Induct.* μ H	Q Min	Test Freq. MHz	SFR Min. MHz	R _{DC} max. Ω	DC Current mA max	Tol** %
MPCI 12 270 000	270	26	0.79	4.0	36	26	5-10
MPCI 12 330 000	330	24	0.79	3.7	42	24	
MPCI 12 390 000	390	24	0.79	3.5	46	23	
MPCI 12 470 000	470	24	0.79	3.0	68	19	
MPCI 12 560 000	560	22	0.79	2.8	77	18	
MPCI 12 680 000	680	20	0.79	2.5	85	17	
MPCI 12 820 000	820	16	0.79	2.0	100	16	
MPCI 12 1000 000	1000	12	0.79	1.5	120	15	

* Standard inductance tolerance: $\pm 10\%$

** Available tolerances.

Other inductance values on request.

Inductance variation: 80 PPM /°C max. in the range 12 to 100 μ H
35 PPM /°C max. in the range 120 to 1000 μ H

Packaging

Tape and Reel (with or without tab): 100 pieces min. up to 500 pieces
or Tray: 81 pieces without tab, 49 pieces with tab

Typical Dimensions (mm)

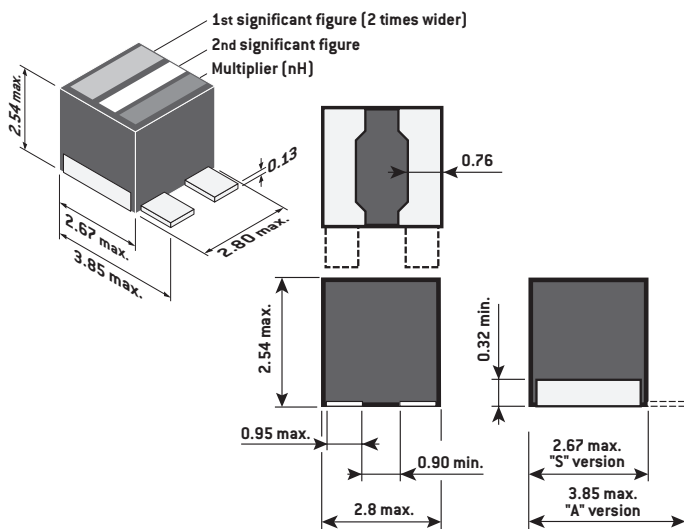

Q vs frequency

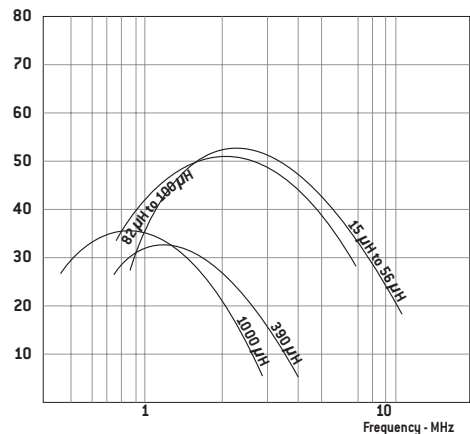

Miniature Chip Inductors MSCI 12000 Series



MPCI 12000 series are usually installed on Military applications and breadboards for Space applications.

Since January 2003, EXXELIA has been manufacturing Radio Frequency Fixed Coils, MPCI 12000 series fulfilling ESA ESCC Generic specification N° 3201 and detail specification N° 3201/008.

This range is named MSCI (S for space applications and without tab).

This qualification approval includes final production tests Chart F2, burn-in and electrical measurements to testing Chart F3 and qualification testing Chart F4.

For procurement, different quality levels are offered:

- Final production tests Chart F2
- Burn-in and electrical measurements Chart F3
- Lot acceptance testing Chart F4 if required

Components delivered through this specification need to be processed and inspected in accordance with the EXXELIA Process Identification Document (P.I.D.).

Each component delivered is traceable to its production lot.

Cross reference chart

EXXELIA Non-QPL ID Code	EXXELIA QPL ID Code	ESA SCC Component Part Number	In accordance to MIL Spec M 83446/6 Part Number	
			Dash number With tabs	Dash number Without tab
MPCI 12 012 000 x y 10/5/2	MSCI 12 012 000 x y 10/5/2	3201008 aa 120 K/J/G	M83446/06-01	M83446/06-25
MPCI 12 015 000 x y 10/5/2	MSCI 12 015 000 x y 10/5/2	3201008 aa 150 K/J/G	M83446/06-02	M83446/06-26
MPCI 12 018 000 x y 10/5/2	MSCI 12 018 000 x y 10/5/2	3201008 aa 180 K/J/G	M83446/06-03	M83446/06-27
MPCI 12 022 000 x y 10/5/2	MSCI 12 022 000 x y 10/5/2	3201008 aa 220 K/J/G	M83446/06-04	M83446/06-28
MPCI 12 027 000 x y 10/5/2	MSCI 12 027 000 x y 10/5/2	3201008 aa 270 K/J/G	M83446/06-05	M83446/06-29
MPCI 12 033 000 x y 10/5/2	MSCI 12 033 000 x y 10/5/2	3201008 aa 330 K/J/G	M83446/06-06	M83446/06-30
MPCI 12 039 000 x y 10/5/2	MSCI 12 039 000 x y 10/5/2	3201008 aa 390 K/J/G	M83446/06-07	M83446/06-31
MPCI 12 047 000 x y 10/5/2	MSCI 12 047 000 x y 10/5/2	3201008 aa 470 K/J/G	M83446/06-08	M83446/06-32
MPCI 12 056 000 x y 10/5/2	MSCI 12 056 000 x y 10/5/2	3201008 aa 560 K/J/G	M83446/06-09	M83446/06-33
MPCI 12 068 000 x y 10/5/2	MSCI 12 068 000 x y 10/5/2	3201008 aa 680 K/J/G	M83446/06-10	M83446/06-34
MPCI 12 082 000 x y 10/5/2	MSCI 12 082 000 x y 10/5/2	3201008 aa 820 K/J/G	M83446/06-11	M83446/06-35
MPCI 12 100 000 x y 10/5/2	MSCI 12 100 000 x y 10/5/2	3201008 aa 101 K/J/G	M83446/06-12	M83446/06-36
MPCI 12 120 000 x y 10/5	MSCI 12 120 000 x y 10/5	3201008 aa 121 K/J/G	M83446/06-13	M83446/06-37
MPCI 12 150 000 x y 10/5	MSCI 12 150 000 x y 10/5	3201008 aa 151 K/J/G	M83446/06-14	M83446/06-38
MPCI 12 180 000 x y 10/5	MSCI 12 180 000 x y 10/5	3201008 aa 181 K/J/G	M83446/06-15	M83446/06-39
MPCI 12 220 000 x y 10/5	MSCI 12 220 000 x y 10/5	3201008 aa 221 K/J/G	M83446/06-16	M83446/06-40
MPCI 12 270 000 x y 10/5	MSCI 12 270 000 x y 10/5	3201008 aa 271 K/J/G	M83446/06-17	M83446/06-41
MPCI 12 330 000 x y 10/5	MSCI 12 330 000 x y 10/5	3201008 aa 331 K/J/G	M83446/06-18	M83446/06-42
MPCI 12 390 000 x y 10/5	MSCI 12 390 000 x y 10/5	3201008 aa 391 K/J/G	M83446/06-19	M83446/06-43
MPCI 12 470 000 x y 10/5	MSCI 12 470 000 x y 10/5	3201008 aa 471 K/J/G	M83446/06-20	M83446/06-44
MPCI 12 560 000 x y 10/5	MSCI 12 560 000 x y 10/5	3201008 aa 561 K/J/G	M83446/06-21	M83446/06-45
MPCI 12 680 000 x y 10/5	MSCI 12 680 000 x y 10/5	3201008 aa 681 K/J/G	M83446/06-22	M83446/06-46
MPCI 12 820 000 x y 10/5	MSCI 12 820 000 x y 10/5	3201008 aa 821 K/J/G	M83446/06-23	M83446/06-47
MPCI 12 1000 000 x y 10/5	MSCI 12 1000 000 x y 10/5	3201008 aa 102 K/J/G	M83446/06-24	M83446/06-48
aa	K/J/G (tolerance)			
aa = 01 for Au Termination	K for ± 10%			
aa = 02 for SnPb Termination	J for ± 5%			
	G for ± 2%			

HIGH GRADE PRODUCTS

To Order

MPCI 12 ### ## x y z

MPCI	12	#####	x	y	z
Radio Frequency Fixed Coils	Size	Inductance Value [nH] from 012 000 to 1000 000	Terminations x = G for Gold x = T for SnPb	Terminations shape y = S without tab y = A with tab (Not valid for space use)	Tolerance: z = 10 for ± 10% z = 5 for ± 5% z = 2 for ± 2%