

# Differential Mode Chokes for DC/DC Embedded Applications - DMC 22 xxx 1WR Series



- Based on EXXELIA's «SESI22 Planar Technology»
- Low-profile SMD package (2 x 4 pins)
- Applied standards: MIL-STD-202, ECSS-Q-70-02, D0-160
- Dielectric strength test up to 500 V (50 Hz - 1 min)
- Materials meet UL94-V0 rating
- Thermal index according to IEC85: H (180°C)
- Operating/storage temperature range: -55°C to +125°C
- Approximative weight: 26 grams

## Electrical Data

ID Code	Inductance Value at 25°C (±40%) L <sub>1-3</sub> = L <sub>5-7</sub>	DC Current max.	max. RMS Current for ΔT = 40°C Heating	max. R <sub>DC</sub> (25°C)	Dielectric Strength (50Hz - 1min)
DMC22 M25 1WR	25 μH	4 A	1 A	60 mΩ	500 Vrms

## Typical Dimensions (mm, top view)

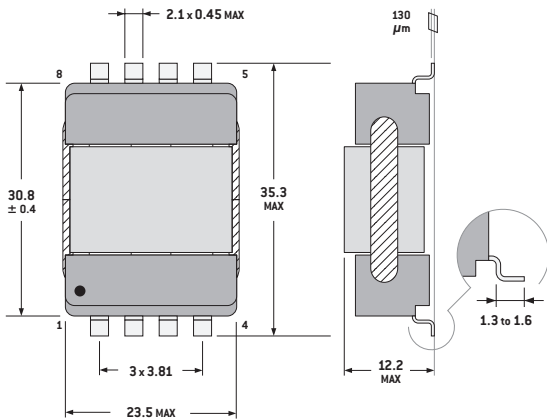

## PCB Layout (suggested)

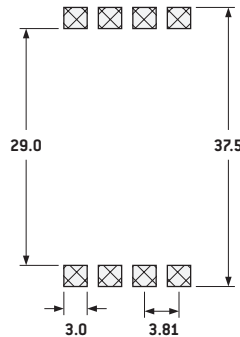

## Connections (Top view)

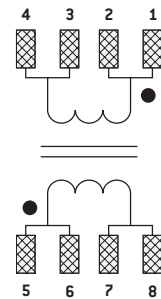

## Packaging

Tape and Reel:  
100 units per reel of diameter 330 mm

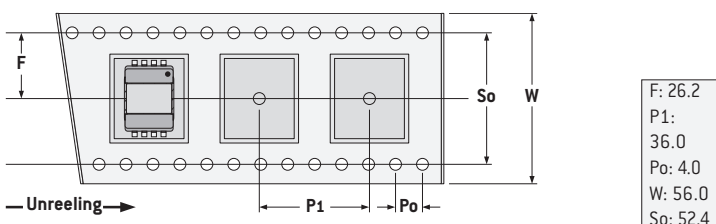

## Marking

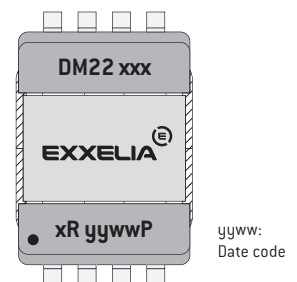

HIGH GRADE PRODUCTS