

WRAP-AND-FILL POLYESTER DIELECTRIC FILM / FOIL CONSTRUCTION



FEATURES

- Extended Foil Construction
- Moisture Resistant

PHYSICAL CHARACTERISTICS

CONSTRUCTION:

Non-inductive wound polyester film and foil.

CASE: Flame retardant tape wrap and epoxy endfill.

LEAD MATERIAL: Solder coated solid wire.

LEAD WIRE SIZES:

Case Dia.	Lead AWG
≤ 0.437	0.025 (No. 22)
> 0.437	0.032 (No. 20)

LEAD STRENGTH:

Capable of withstanding a five pound pull force on lead axis.

MARKING:

Dearborn trademark, type or catalog number, capacitance, tolerance and voltage.

ELECTRICAL SPECIFICATIONS

CAPACITANCE RANGE: 0.001 μ F to 5.0 μ F

VOLTAGE RATING:

- 50 VDC to 600 VDC
- 32 VAC to 220 VAC

CAPACITANCE TOLERANCE: $\pm 20\%$, $\pm 10\%$, $\pm 5\%$

OPERATING TEMPERATURE: -55°C to $+125^{\circ}\text{C}$

DISSIPATION FACTOR: 1.0%, maximum

VOLTAGE DERATING:

- At $+105^{\circ}\text{C}$, 70% of the 85°C rating
- At $+125^{\circ}\text{C}$, 50% of the 85°C rating

VOLTAGE TEST: 200% of rated voltage for 1 minute

INSULATION RESISTANCE:

- At $+25^{\circ}\text{C}$, 50,000 Megaohm-Microfarads, need not exceed 100,000 Megaohms
- At $+85^{\circ}\text{C}$, 2,500 Megaohm-Microfarads, need not exceed 5,000 Megaohms
- At $+105^{\circ}\text{C}$, 1,000 Megaohm-Microfarads, need not exceed 2,000 Megaohms
- At $+125^{\circ}\text{C}$, 10 Megaohm-Microfarads, need not exceed 150 Megaohms

MAXIMUM PULSE RISE TIME

Capacitor Length (inch)	Rise Time dv / dt (V / μ s)				
	50 VDC	100 VDC	200 VDC	400 VDC	600 VDC
0.450	-	1000	-	-	-
0.531	735	-	-	-	-
0.594	540	-	-	-	-
0.656	360	-	-	-	-
0.718	288	288	413	875	1563
0.750	275	-	-	-	-
0.812	252	-	-	-	-
0.844	-	219	268	620	1050
0.875	-	-	-	-	1018
0.969	-	-	217	-	-
1.000	-	-	180	475	764
1.062	161	-	-	-	-
1.250	-	127	160	329	515
1.375	124	-	-	-	-
1.562	-	114	137	310	359
1.625	110	-	-	-	-
1.750	-	-	124	290	-
1.875	100	-	110	-	-
1.937	-	100	-	250	344
2.125	75	-	-	-	316
2.375	-	90	100	185	261
2.625	-	74	90	-	234
3.062	-	-	83	-	-

DIMENSIONS (in inches)

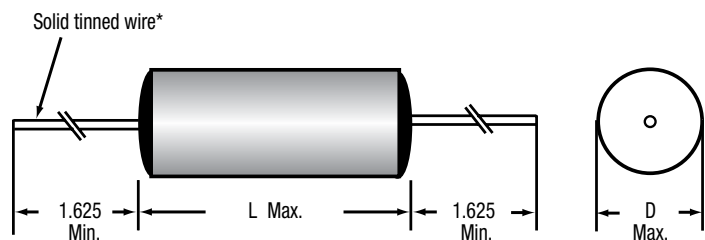

* Leads to be within $\pm 0.062''$ of center line at egress, but not less than 0.031" from edge.

WRAP-AND-FILL POLYESTER DIELECTRIC FILM / FOIL CONSTRUCTION

TYPE 410P

STANDARD RATINGS

Capacitance		Voltage Code 050 50 VDC / 32 VAC*		Voltage Code 100 100 VDC / 63 VAC*		Voltage Code 200 200 VDC / 126 VAC*		Voltage Code 400 400 VDC / 200 VAC*		Voltage Code 600 600 VDC / 220 VAC*	
µF	Code	D	L	D	L	D	L	D	L	D	L
0.0010	102	-	-	-	-	0.190	0.450	0.190	0.718	0.190	0.718
0.0015	152	-	-	-	-	0.190	0.450	0.190	0.718	0.190	0.718
0.0022	222	-	-	-	-	0.190	0.450	0.190	0.718	0.190	0.718
0.0033	332	-	-	-	-	0.190	0.450	0.190	0.718	0.205	0.718
0.0047	472	-	-	-	-	0.190	0.450	0.190	0.718	0.235	0.718
0.0068	682	-	-	0.190	0.450	0.190	0.718	0.190	0.718	0.240	0.844
0.010	103	-	-	0.190	0.450	0.190	0.718	0.200	0.844	0.270	0.844
0.015	153	0.190	0.531	0.190	0.718	0.190	0.718	0.230	0.844	0.315	0.875
0.022	223	0.200	0.594	0.190	0.718	0.190	0.718	0.265	0.844	0.375	0.875
0.033	333	0.210	0.656	0.190	0.718	0.190	0.844	0.315	0.875	0.395	1.000
0.047	413	0.215	0.718	0.215	0.718	0.210	0.844	0.325	1.000	0.400	1.250
0.068	683	0.250	0.718	0.215	0.844	0.240	0.844	0.340	1.250	0.455	1.250
0.10	104	0.290	0.750	0.245	0.844	0.275	0.969	0.400	1.250	0.470	1.562
0.15	154	0.312	0.812	0.285	0.844	0.345	1.000	0.405	1.562	0.545	1.562
0.22	224	0.315	1.062	0.290	1.250	0.355	1.250	0.480	1.562	0.590	1.937
0.33	334	0.375	1.062	0.325	1.250	0.425	1.250	0.650	1.750	0.800	1.937
0.47	474	0.430	1.062	0.380	1.250	0.440	1.562	0.725	1.937	0.890	2.125
0.68	689	0.450	1.375	0.455	1.562	0.610	1.750	0.750	2.375	0.980	2.375
1.00	105	0.500	1.375	0.535	1.562	0.710	1.875	0.900	2.375	-	-
1.50	155	0.640	1.625	0.645	1.937	0.730	2.375	-	-	-	-
2.00	205	0.730	1.625	0.715	1.937	0.800	2.375	-	-	-	-
2.50	255	0.750	1.875	0.715	2.375	0.834	2.625	-	-	-	-
3.00	305	0.830	1.875	0.770	2.375	0.905	2.625	-	-	-	-
4.00	405	0.850	2.125	0.830	2.625	0.945	3.062	-	-	-	-
5.00	505	0.940	2.125	0.915	2.625	-	-	-	-	-	-

Additional capacitance values, voltages, and tolerances are available upon request.

* AC voltage rating is at 60Hz 1.4 x VRMS + VDC should not exceed the rated VDC.

TYPICAL CHARACTERISTICS POLYESTER FILM / FOIL TYPES

TYPICAL CHARACTERISTICS

CAPACITANCE CHANGE VS. TEMPERATURE

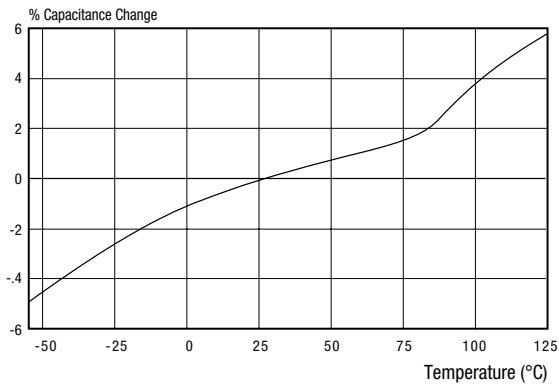

INSULATION RESISTANCE VS. TEMPERATURE

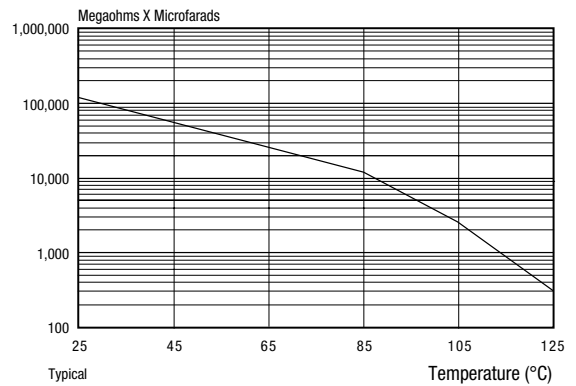

DISSIPATION FACTOR VS. TEMPERATURE

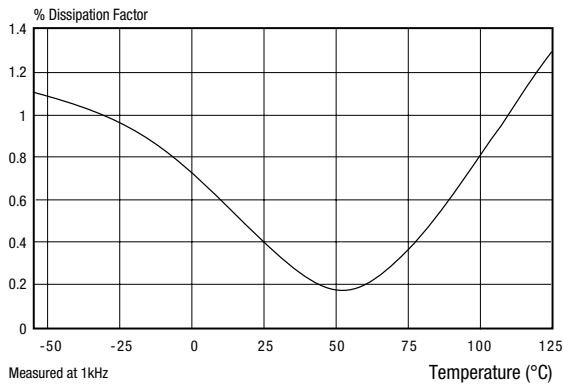

GUIDE TO ORDERING

SECTION GROUNDED TO CASE

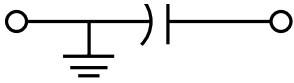

DIMENSIONS (in inches)

CASE STYLE 01

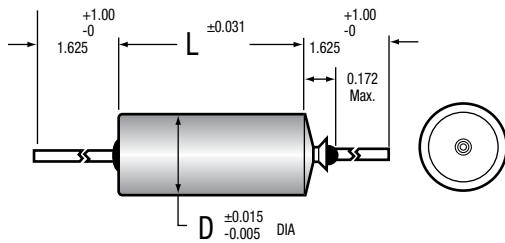

CASE STYLE 03

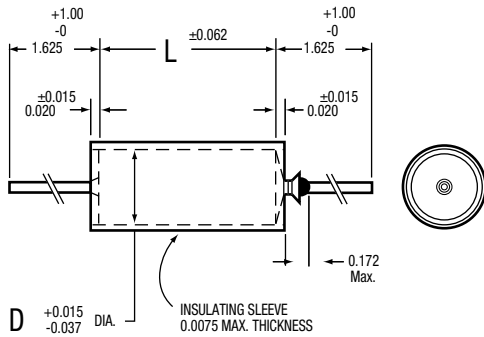

CASE STYLE 12

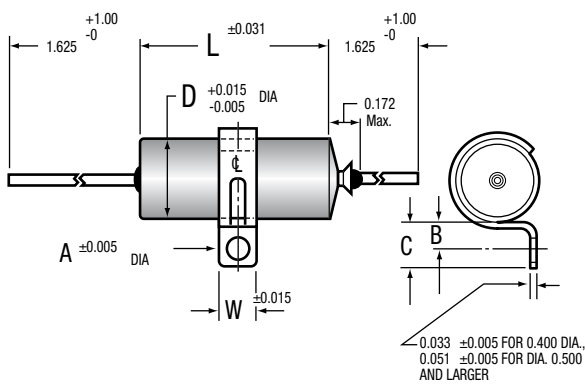

SECTION INSULATED FROM CASE

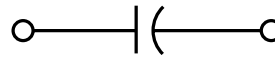

DIMENSIONS (in inches)

CASE STYLE 02

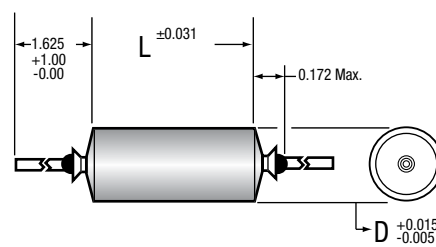

CASE STYLE 04

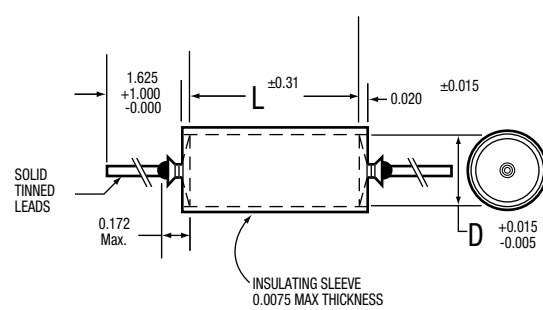

CASE STYLE 13

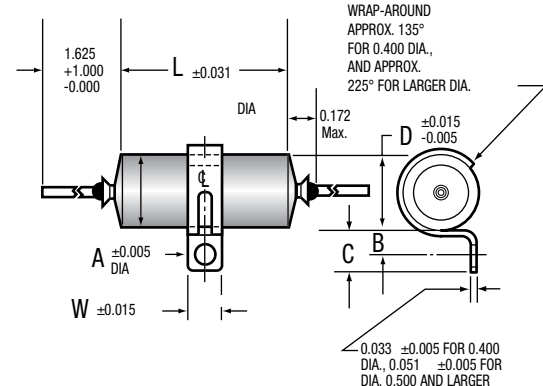

The length of grounded styles is 0.062" shorter than the length shown in tabulations in the catalog.

GUIDE TO ORDERING

BRACKET DIMENSIONS (Style 12 & 13 / in inches)

D	W	A	B	C
0.400	0.250	0.144	0.187±0.015	0.312±0.031
0.500	0.500	0.156	0.250±0.031	0.437±0.062
0.562	0.500	0.156	0.250±0.031	0.437±0.062
0.670	0.500	0.156	0.250±0.031	0.437±0.062
0.750	0.500	0.156	0.250±0.031	0.437±0.062
1.000	0.500	0.156	0.250±0.031	0.437±0.062

*Based on 1 in. = 25.4 mm

TYPICAL TAB TERMINAL DIMENSIONS

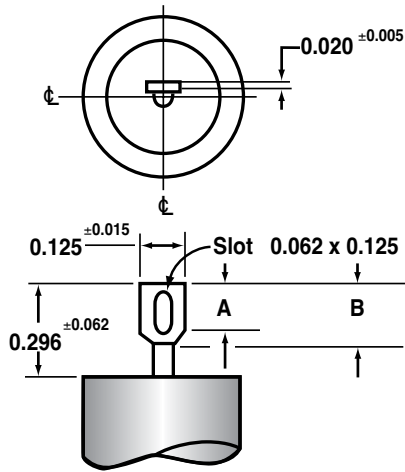

Dwg. No A-9525

A = 0.156 ± 0.015" (3.96 ± 0.38 mm)

B = 0.187 ± 0.015" (4.75 ± 0.38 mm)

Tab Terminal available only on case diameters equal to or greater than 0.400 inches.

T1 & T3 styles are supplied with one tab terminal on the insulated end and a ground lead on the opposite end.

METAL CASE

EXAMPLE:

218P

223

X9

100

S

02

CATALOG NUMBERING SYSTEM

Case style

Terminal: S = Wire leads T = Soldering tab*.

DC Voltage rating: Expressed in volts.
See standard ratings charts for voltage code.

Capacitance Tolerance: X0 = $\pm 20\%$
X9 = $\pm 10\%$
X5 = $\pm 5\%$
X2 = $\pm 2\%$

Capacitance: Expressed in picofarads, the first two digits are significant figures; the third is the number of zeros following. See standard ratings tables for capacitance code.

Dearborn type number: Identifies the basic capacitor.

* Soldering tabs are available only on case diameters equal to or greater than 0.400 inches.

WRAP AND FILL

EXAMPLE:

430P

183

X9

100

X

F

CATALOG NUMBERING SYSTEM

"F" applies only to "ROHS" compliant parts.

Terminal: No suffix required unless specified on applicable specification sheet (Terminal style).

DC Voltage rating: Expressed in volts.
See standard ratings charts for voltage code.

Capacitance Tolerance: X0 = $\pm 20\%$
X9 = $\pm 10\%$
X5 = $\pm 5\%$
X2 = $\pm 2\%$

Capacitance: Expressed in picofarads, the first two digits are significant figures; the third is the number of zeros following. See standard ratings tables for capacitance code.

Dearborn type number: Identifies the basic capacitor.

PROPERTIES OF DIELECTRIC FILMS

POLYESTER (Polyethylene Terephthalate, P.E.T.)

Capacitors with smaller dimensions can be manufactured due to the high dielectric constant and excellent electrical performance of this film. Metalized polyester capacitors also have outstanding self-healing properties.

POLYPROPYLENE (P.P.)

This film features very low dielectric losses, low dielectric adsorption, high dielectric strength, very high insulating strength and a practically linear temperature coefficient in all temperature ranges.

All these properties make this film suitable for the manufacturing of power electronics capacitors.

However, the operating temperature is limited to 105°C.

POLYPHENYLENE SULFIDE (P.P.S.)

The properties of this film are as follows: very low dielectric losses, low temperature coefficient, high stability of the capacitance value, resistant to humidity and a high melting point. This material is suited for surface mounted precision capacitors (SMD). This film also has high temperature advantages and can be used for temperature up to 150°C.

PROPERTIES OF METALIZED FILM CAPACITORS

The metalized film consists of an extremely thin layer (some hundredths μm) of zinc or aluminum deposited by evaporation under vacuum on the dielectric. The nature, thickness and geometry of the metalized layer modify the properties of the capacitors, especially as far as permissible peak or effective current is concerned.

Metalized film capacitors are smaller than film-foil capacitors.

Self-healing is a fundamental property of these capacitors. When a dielectric breakdown occurs between the metal layers, due to a dielectric failure, an electrical arc causes local vapor deposition of the metallization which results in an insulating metallic oxide. Thus regenerated, the capacitor is once again operational.

The self-healing operation generally requires only a very small amount of energy (5 to 15 μJoules) and is performed in several $\mu\text{seconds}$ (< 50). However, a minimum amount of energy is required below which self-healing operations are unpredictable. This energy is calculated in relation to the capacitance value and the load voltage: $E = 1 / 2 CV^2$.

PROPERTIES OF FILM-FOIL CAPACITORS

Film Foil capacitors are especially recommended to meet high voltage or current and / or power stresses.

The thickness of the metal foil enables the reduction of the series resistance and improves the general performance of the capacitors. These improvements are made to the detriment of the volume of the capacitor which also loses its self-healing properties. Composite dielectrics combine films of different types with complementary specific characteristics.

For high voltage and power electronics applications, these capacitors are usually impregnated with impregnating fluids or solid substances.

CAPACITOR PERFORMANCE VS. TEMPERATURE

The capacitors' performance versus temperature essentially depends upon the dielectric type.

The figure below shows ranges of operating temperatures.

% OF CAPACITANCE CHANGE VS. TEMPERATURE (°C)

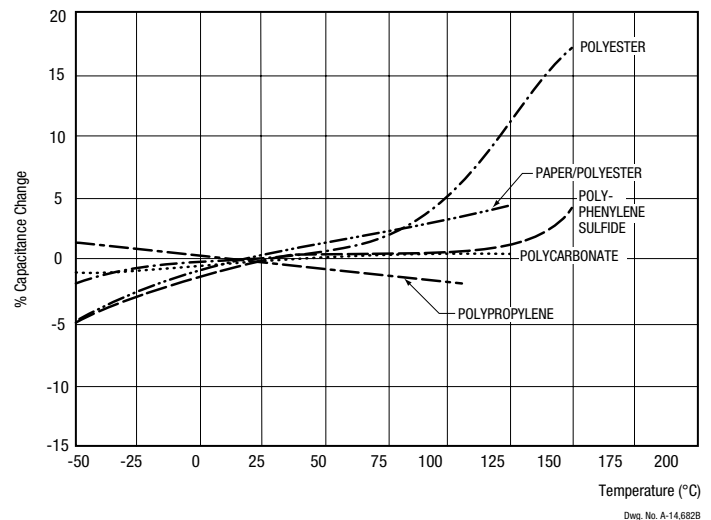

Important differences affect the laws governing the changes of the main electrical characteristics.

They are highlighted by the following curves:

% OF DISSIPATION FACTOR (DF) VS. TEMPERATURE (°C)

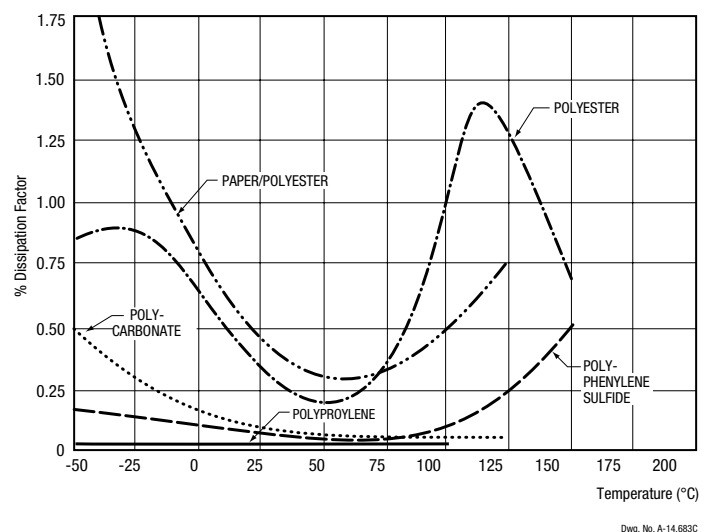

PROPERTIES OF DIELECTRIC FILMS

% OF DISSIPATION FACTOR (DF) VS. FREQUENCY (HZ)

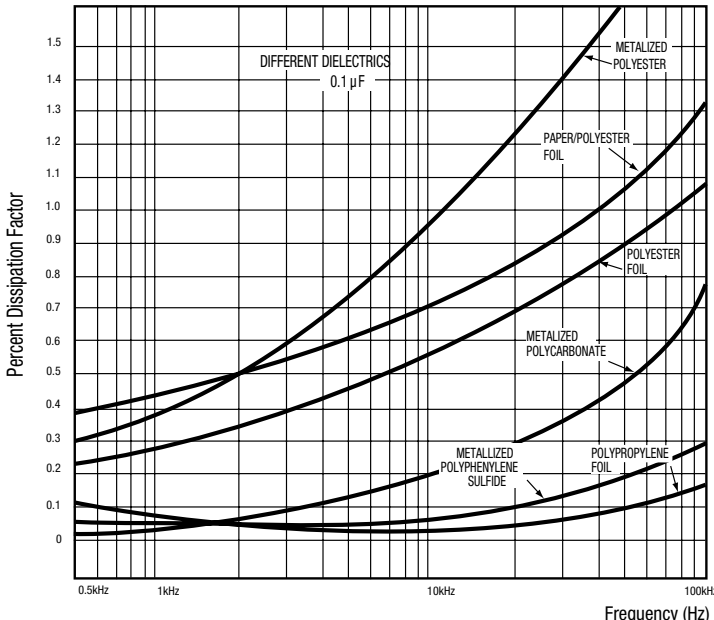

A REAL CAPACITOR MAY BE REPRESENTED BY THE FOLLOWING DIAGRAM:

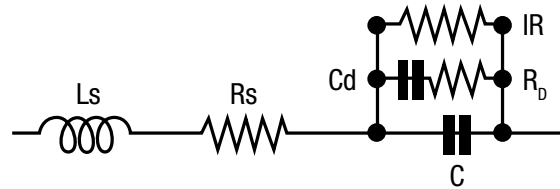

Series Inductance	Ls
Resistance of metal foil & connections	Rs
Insulation Resistance	IR
Dielectric Absorption	Cd
Resistance equivalent to the dielectric losses	R _D
Capacitance	C

Resistive terms generate temperature rises when the capacitors carry AC current (I_{rms}). Depending upon the frequency range, they may be more or less preponderant.

THE EQUIVALENT SERIES RESISTANCE (ESR) IS THE SUM OF THE FOLLOWING TERMS:

$$ESR = R_s + DF / C\omega + 1 / IR C^2 \omega^2$$

When the frequency increases, the term $1 / IRC^2\omega^2$ becomes rapidly insignificant.

For plastic dielectrics, losses remain constant within a wide range of frequencies and the affect of the term: $DF / C\omega$ decreases: $ESR = R_s + DF / C\omega$

The metal foil and the connections are designed to obtain a resistance value (R_s) as low as possible. This value is dependent on the capacitors' technology and geometry.

Inductance (L_s) also disturbs the equation of the capacitors at high frequencies.

IMPEDANCE (Z) IS STATED AS FOLLOWS:

$$Z = R_s^2 + (L_s\omega - 1 / C\omega)^2$$

When frequency increases, the affect of L_s will gradually cancel the capacitance component of the capacitors until it reaches the resonance frequency where:

$$Z = R_s \text{ and } LC\omega^2 = 1$$

IR VS. TEMPERATURE (°C)

